



# NAVAL POSTGRADUATE SCHOOL

MONTEREY, CALIFORNIA

**Barrier Games**

by

Alan R. Washburn

June 2009

**Approved for public release; distribution is unlimited**

Prepared for: Department of Operations Research  
Naval Postgraduate School, Monterey, CA 93943

THIS PAGE INTENTIONALLY LEFT BLANK

**NAVAL POSTGRADUATE SCHOOL  
MONTEREY, CA 93943-5001**

Daniel T. Oliver  
President

Leonard A. Ferrari  
Executive Vice President and  
Provost

This report was prepared for and funded by the Operations Research Department, Naval Postgraduate School, Monterey, California 93943.

Reproduction of all or part of this report is authorized.

This report was prepared by:

---

ALAN R. WASHBURN  
Professor of Operations Research

Reviewed by:

---

R. KEVIN WOOD  
Associate Chairman for Research  
Department of Operations Research

Released by:

---

ROBERT F. DELL  
Chairman  
Department of Operations Research

---

KARL VAN BIBBER  
Vice President and  
Dean of Research

THIS PAGE INTENTIONALLY LEFT BLANK

<b>REPORT DOCUMENTATION PAGE</b>			<i>Form Approved OMB No. 0704-0188</i>
Public reporting burden for this collection of information is estimated to average 1 hour per response, including the time for reviewing instruction, searching existing data sources, gathering and maintaining the data needed, and completing and reviewing the collection of information. Send comments regarding this burden estimate or any other aspect of this collection of information, including suggestions for reducing this burden, to Washington headquarters Services, Directorate for Information Operations and Reports, 1215 Jefferson Davis Highway, Suite 1204, Arlington, VA 22202-4302, and to the Office of Management and Budget, Paperwork Reduction Project (0704-0188) Washington DC 20503.			
<b>1. AGENCY USE ONLY (Leave blank)</b>	<b>2. REPORT DATE</b> June 2009	<b>3. REPORT TYPE AND DATES COVERED</b> Technical Report	
<b>4. TITLE AND SUBTITLE:</b> Barrier Games			<b>5. FUNDING NUMBERS</b>
<b>6. AUTHOR(S)</b> Alan R. Washburn			
<b>7. PERFORMING ORGANIZATION NAME(S) AND ADDRESS(ES)</b> Naval Postgraduate School Monterey, CA 93943-5000			<b>8. PERFORMING ORGANIZATION REPORT NUMBER</b>
<b>9. SPONSORING /MONITORING AGENCY NAME(S) AND ADDRESS(ES)</b> N/A			<b>10. SPONSORING/MONITORING AGENCY REPORT NUMBER</b>
<b>11. SUPPLEMENTARY NOTES</b> The views expressed in this report are those of the author and do not reflect the official policy or position of the Department of Defense or the U.S. Government.			
<b>12a. DISTRIBUTION / AVAILABILITY STATEMENT</b> Approved for public release; distribution is unlimited			<b>12b. DISTRIBUTION CODE</b> A
<b>13. ABSTRACT (maximum 200 words)</b> This report considers barriers that separate one region from another in the sense that an intruder cannot pass from one region to the other without being captured. The barriers are composed of individual units, each of which has a fixed speed and capture radius. The distinguishing feature is that the intruder is assumed to know the configuration of the barrier at all times, and can use this information to select a successful penetration path, if one exists. We find conditions under which penetration is possible, first for straight-line barriers and then for circular barriers.			
<b>14. SUBJECT TERMS</b> Barrier, Game			<b>15. NUMBER OF PAGES</b> 38
			<b>16. PRICE CODE</b>
<b>17. SECURITY CLASSIFICATION OF REPORT</b> Unclassified	<b>18. SECURITY CLASSIFICATION OF THIS PAGE</b> Unclassified	<b>19. SECURITY CLASSIFICATION OF ABSTRACT</b> Unclassified	<b>20. LIMITATION OF ABSTRACT</b> UU

THIS PAGE INTENTIONALLY LEFT BLANK

## ABSTRACT

This report considers barriers that separate one region from another in the sense that an intruder cannot pass from one region to the other without being captured. The barriers are composed of individual units, each of which has a fixed speed and capture radius. The distinguishing feature is that the intruder is assumed to know the configuration of the barrier at all times, and can use this information to select a successful penetration path, if one exists. We find conditions under which penetration is possible, first for straight-line barriers and then for circular barriers.

THIS PAGE INTENTIONALLY LEFT BLANK



# TABLE OF CONTENTS

I.	INTRODUCTION AND SUMMARY.....	1
II.	STRAIGHT LINE BARRIERS.....	3
A.	UNIDIRECTIONAL STRAIGHT-LINE BARRIERS.....	3
B.	DIRECTIONALLY REVERSING STRAIGHT-LINE BARRIERS.....	6
1.	Setup Time for a Trial.....	6
2.	Trial Details.....	7
3.	Mean Time to Penetration.....	9
C.	SINGLE SEARCHER.....	9
II.	CIRCULAR BARRIERS.....	13
A.	THE CASE: $\rho^2 + \mu^2 \leq 1$ .....	18
B.	THE CASE: $\rho^2 + \mu^2 > 1$ .....	20
C.	SUMMARY OF THE CIRCULAR CASE.....	23
D.	BARRIER REVERSALS.....	24
	LIST OF REFERENCES.....	25
	INITIAL DISTRIBUTION LIST.....	27

THIS PAGE INTENTIONALLY LEFT BLANK

## I. INTRODUCTION AND SUMMARY

Military forces have always used barriers to prevent the incursion of enemy units into protected areas. The use of pickets around a campsite or guards at the entrance to a building or base are examples. The barriers are often composed of individual units with their own sensors, such as a blockade of a port by several ships. In circumstances where a long barrier without natural obstructions must be held, these units sometimes attempt to increase their effectiveness by continually moving. There are two arguments in favor of movement. One is that movement tends to confuse potential infiltrators about the exact location of the barrier, and therefore makes penetration a risky endeavor. The other argument is that movement provides a kind of dynamic enhancement, especially against relatively slow infiltrators. Both reasons will be dealt with in this report.

The antisubmarine operations of World War Two included the establishment of several barriers against submarine movement. One was across the Strait of Gibraltar, where Allied aircraft and ships attempted to prevent the movement of German submarines from the Atlantic into the Mediterranean. Koopman (1980) reports some formulas for detection probability in such circumstances, and Washburn (1982) revisits the same subject. These formulas include the effect of dynamic enhancement, which was significant because submarines of the era were relatively slow. All of this work makes the presumption that the potential infiltrators do not know the exact disposition of the moving units that constitute the barrier; that is, they are “dumb”. Given the primitive sensors possessed by submarines at the time, that was a reasonable presumption in World War Two. It might still be a good assumption for antisubmarine barriers composed of aircraft, but modern submarines tend to have a good idea of the locations of any surface ships in the vicinity. That fact has prompted the current work, which is an investigation of the efficacy of barriers when infiltrators are perfectly informed (“smart”) about the locations of the barrier components.

Our smart infiltrator will be called the Evader, or “E”, for short. E can observe the movements of the barrier units, and is free to attempt penetration at any time and in any manner that he chooses, except that his speed is at all times limited to  $U$ . The barrier elements have maximum speed  $V$ , and can detect E within a distance  $r$ . The question is whether E can go from one side of the barrier to the other without coming within  $r$  of some barrier unit. Since the barrier must be designed in the knowledge that the design will be observed and exploited by E, the situation is really a two-person zero-sum game; hence the title of this report.

We consider two kinds of barriers: straight-line and circular. In the straight-line case, the barrier consists of infinitely many capture circles arranged on a line with spacing  $S$ . When the barrier line always moves in one direction, we find that penetration is possible if and only if  $SU \geq 2r \max(U, V)$ . The counterpart to this criterion in the case of a dumb infiltrator is Koopman’s World War Two formula for the probability of detection:  $P = \min(1, \frac{2r}{SU} \sqrt{V^2 + U^2})$ . Our smart E can sometimes penetrate even when this probability is one. For example, if  $(r, S, U, V) = (3, 10, 3, 4)$ , then  $P = 1$ , but E can still penetrate the barrier according to our criterion.

Somewhat surprisingly, the penetration criterion does not change even if the barrier line occasionally reverses direction. If E is disappointed by a direction reversal, as can certainly happen, then he simply retreats, thereby avoiding capture, to try again another time. He will eventually succeed in penetrating the barrier as long as time is not limited and  $SU \geq 2r \max(U, V)$ . The first argument in favor of movement is thus found to be ineffective when E is smart; there is nothing to be gained by making the barrier's movement random, other than delay of the inevitable.

In the case of circular barriers, let  $R$  be the radius of the circle and  $n$  the number of capture circles on its circumference. E's objective is now to get from outside the barrier circle to its center, or vice versa, without coming too close to a capture circle. Since the distance between capture circles is  $S = 2\pi R/n$ , one might apply the linear criterion and conclude that penetration is possible if and only if  $\pi RU \geq nrV$ , at least when  $V$  is larger than  $U$ . This turns out to be true in most cases, but there are some exceptions. Direction reversals are again found to be ineffective.

## II. STRAIGHT-LINE BARRIERS

### A. UNIDIRECTIONAL STRAIGHT-LINE BARRIERS

Figure 1 depicts a straight-line barrier as a horizontal strip composed of capture circles, all of which have radius  $r$ , the capture distance. Only two circles are shown, but there are actually infinitely many of them, spaced  $S$  apart on the barrier line, and they all move to the right at the same speed  $V$ . An evader  $E$  with maximum speed  $U$  and infinite endurance desires to cross the barrier without entering any of the capture circles. Is it possible for  $E$  to do that? Answering the question is the subject of this section. The shaded regions, the “gap”  $G$ , the “base”  $B$ , and the angle  $\phi$  in Figure 1 will be explained below.

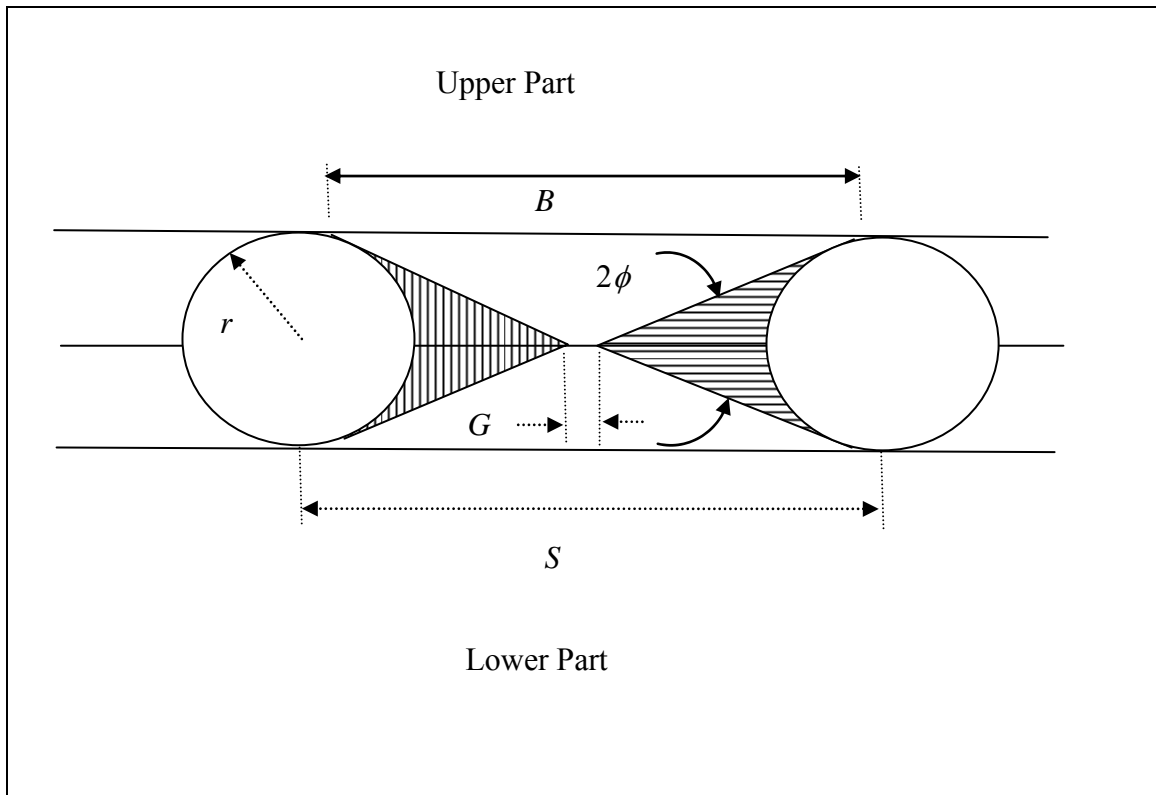

**Figure 1. Illustrating two of infinitely many capture circles on a barrier line.**

To be precise, here is what we mean by “cross the barrier”. The barrier line itself is the center of a strip of height  $2r$  that includes all of the capture circles; call it the “barrier strip” BS. The strip BS divides the upper part of the plane from the lower part.  $E$  is assumed to start somewhere in the upper part. If he succeeds in moving to the lower part by transiting BS without entering the interior of any of the capture circles, then he has crossed the barrier. It does not matter where  $E$  starts in the upper part, since he can

move anywhere else in a straight line without fearing capture, so his exact position is not specified. There is no time constraint. It is clear that E could just as well desire to transit from the lower part to the upper part, or that the barrier could be moving to the left instead of to the right, but it is convenient to be definite.

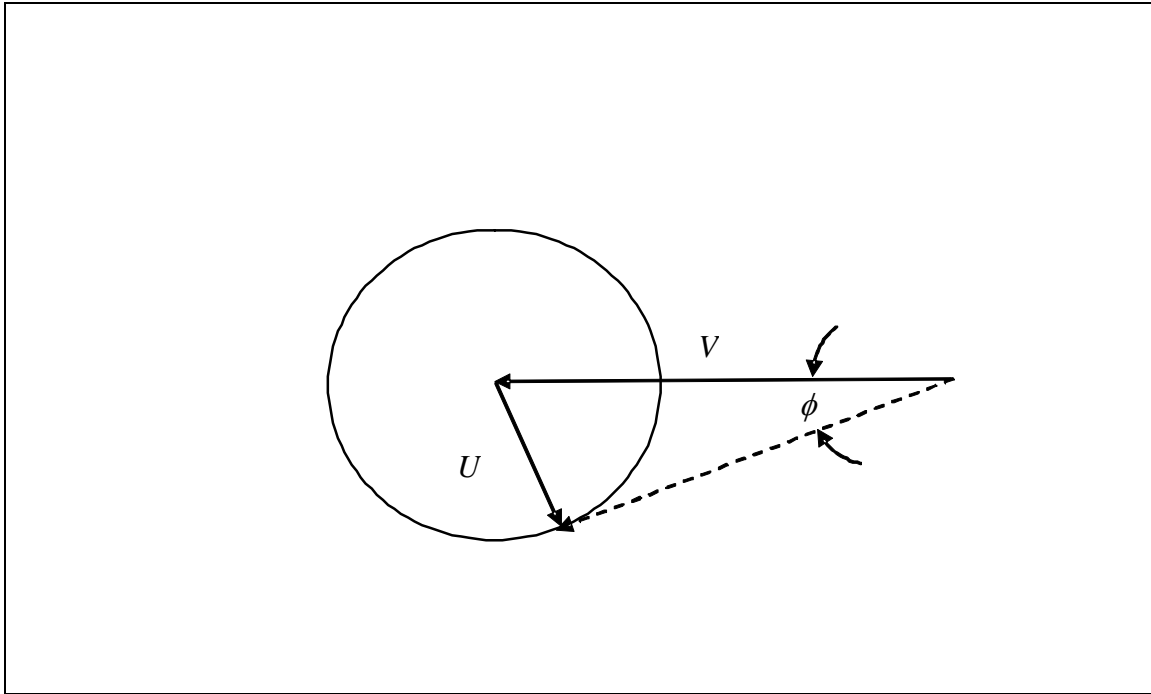

**Figure 2. Illustrating the cone of feasible directions.**

The speeds of both E and the barrier are given relative to the medium within which both are moving, perhaps the ocean. While conducting an analysis relative to that medium might seem natural, there is much to be said for a frame of reference where the barrier is stationary. We therefore adopt a Cartesian coordinate system within which the barrier is stationary. In that system, E is subject to a drift of magnitude  $V$  directed to the left, as shown in Figure 2. Also shown is the circle of possible relative velocities for E, with each feasible velocity starting at the base of the drift vector and ending at some point in or on a circle with radius  $U$ . Only one of the possible resultant velocities is illustrated (shown dashed), but any velocity in or on the circle can be achieved by E, since E controls the magnitude and direction of  $U$ . All feasible directions lie within a cone whose apex angle is  $2\phi$ , where  $\phi$  is the maximum absolute deflection from drift that E can achieve. This is the cone of feasible directions. Since an extreme direction such as the one illustrated will be tangent to the circle, we have  $\sin(\phi)=U/V$ . If E chooses to move at maximum deflection as shown in Figure 2, his velocity vector will be perpendicular to the direction of relative motion. In that case, we will describe E as “leading” the barrier because, relative to the medium, the horizontal component of E’s velocity is in the same direction as the barrier’s velocity. When the barrier is moving to the right, E’s movement in the medium is also to the right, but nonetheless to the left, relative to the barrier, as shown in Figure 2.

If  $U > V$ , the problem is of little interest because all directions are feasible. E can surely cross the barrier safely as long as  $2r \leq S$  (we require that E be strictly inside a capture circle for him to be captured, hence the strict inequality), or else can surely not cross the barrier safely if  $2r > S$ .

Figure 1 applies to the case  $U \leq V$ . It illustrates two shaded “dunce caps” attached to the two circles. The one on the left (vertical shading) has the property that E will surely be captured if he ever enters the interior of the dunce cap. This is true because the sides of the dunce cap are, by construction, parallel to the sides of the cone of feasible directions, so any feasible direction will ultimately lead to E passing through the left-hand circle. Call the left-hand dunce cap the “capture region” CR. E will be captured if he starts from within CR, or enters CR at any time, but can escape being captured by the left-hand circle if he starts from any position outside of CR.

The right-hand dunce cap (horizontal shading) in Figure 1 is not a capture region, but instead is a set of positions that cannot be reached without having been in the right-hand circle at some time in the past. Call it the Exclusion region, ER. Unless E starts within ER, he cannot enter ER without first entering the right-hand circle. Since ER is contained in BS, and since E does not start in BS, an uncaptured E cannot be in ER.

Figure 1 shows a gap G between the apexes of CR and ER. As long as  $U \leq V$ , the distance from the apex of CR to the center of its circle is  $r/\sin(\phi)$ , and the half-length of the gap is therefore  $S/2 - rV/U$ . If  $U > V$ , then E can move anywhere he wishes, the dunce caps are null, and the half length is  $S/2 - r$ . A generally valid formula for the half length is thus

$$g = S/2 - r \max(U, V)/U . \quad (2.1)$$

As long as  $g \geq 0$ , E can penetrate the barrier. If  $U \leq V$ , he can do so on a straight line track parallel to the upper part of ER that goes through the center of G. Such a track can be achieved as pictured in Figure 2, with E orienting his velocity both downward and to the right. The result is that he moves downward and to the left relative to the barrier. On the other hand, E cannot cross the barrier between the two circles if  $g < 0$ , since all parts of the barrier line lead to capture either in the past (ER) or the future (CR). We can conclude that penetration is possible if and only if  $SU \geq 2r \max(U, V)$ , thus answering the question posed earlier. The one exception to this is if  $U = V$  and  $S = 2r$ , in which case penetration is not possible because E’s speed, relative to the barrier, is 0 when he leads the barrier.

If  $g \geq 0$ , and if the barrier is composed of sentient searchers who wish to prevent penetration, the obvious remedy would be to reduce  $S$  until  $g < 0$ . We assume that this is impossible because there are not enough searchers. An alternative would be to occasionally reverse the direction of barrier movement, thus introducing the possibility that E might be captured when the barrier direction reverses at an awkward (for E) moment. Such tactics are the subject of the next section.

## B. DIRECTIONALLY REVERSING STRAIGHT-LINE BARRIERS

In this subsection (and all of its sub-subsections), we will establish that barrier reversals won't prevent penetration as long as  $E$  has no time constraint. We assume  $g \geq 0$ , since otherwise the barrier works even without reversals, and we also assume  $U \leq V$ , since otherwise the faster  $E$  can easily penetrate. Recall that the barrier consists of infinitely many equally-spaced capture circles, even though only two are shown in Figure 1. We begin with the following observation:

**Reversability Observation:** Let  $U(t)$  be  $E$ 's velocity at time  $t$ , let  $V_i(t)$  be the velocity of the  $i^{\text{th}}$  capture circle at time  $t$ , and suppose that  $E$  moves from point  $A$  at time  $t_1$  to point  $B$  at time  $t_2$  without being captured by any of the circles. Then, if the direction of motion of all of the capture circles is reversed,  $E$  can move from  $B$  at time  $t_1$  to  $A$  at time  $t_2$  by reversing the direction of  $U(t)$ .

We omit the proof. Reversing all velocity directions has the effect of playing a movie backwards, and  $E$  won't run into any circles when time is reversed if and only if he doesn't run into any circles when time runs forward.

One consequence of the reversibility observation is that, if  $E$  attempts to penetrate the barrier when  $g \geq 0$  using the tactic described above, and if the barrier reverses direction at a time that threatens capture, then (since barrier reversal reverses the direction of all of the capture circles),  $E$  can escape capture by simply turning around and going back where he came from. While barrier penetration has failed,  $E$  can always try again later. Of course,  $E$  could also persist with his penetration attempt, gambling that the barrier's direction will reverse again before he is captured, but  $E$  does not need to gamble. We will show that  $E$  can always penetrate the barrier without risk, provided he is patient.

It is not possible to give an upper bound on the amount of time required for  $E$  to penetrate the barrier. This should be obvious, since  $E$  is not in control of the barrier's reversals. We can, however, give an upper bound on the *average* amount of time required for  $E$  to penetrate the barrier. To guarantee this upper bound,  $E$  will use a tactic that amounts to a succession of independent penetration trials, each of which has a positive probability of success. We assume that  $E$  begins on the upper boundary of  $BS$ , which is the same as the lower boundary of the upper part shown in Figure 1. It will be useful to think of the upper boundary being partitioned into segments, with each segment lying above a neighboring pair of circle centers.

### 1. Setup Time for a Trial

Each trial begins by selecting a particular point  $Y$  on some segment for a starting point. The exact method of selecting  $Y$  is not important for the moment, except that it does not matter which segment  $Y$  is located on. In order to begin the next trial,  $E$  must first get to  $Y$  from his current position  $X$ . This can be nontrivial unless  $Y$  happens to be  $X$ , since  $E$  is not in control of the barrier's course reversals. We will investigate a particular



tactic by which E can nonetheless move from  $X$  to  $Y$ . The tactic involves a sequence of attempts to get to  $Y$ , one of which must eventually succeed. Here it is:

1. Flip a coin. If it is “heads” (“tails”), move to the right (left) at top speed for a distance  $S$ , the length of one segment. During this time, it may happen that E’s position relative to the barrier is  $Y$  at some time. If that happens, the attempt to attain  $Y$  succeeds at that time. If it does not, the attempt fails.
2. Repeat until some attempt succeeds.

Suppose first that  $Y$  is larger than  $X$ . There are only two possibilities: either the net movement of the barrier over the time  $S/U$  is to the right or the left. If the barrier moves to the left, then the attempt will succeed if the coin is “heads”. This is because the distance from E to  $Y$  is positive at the start of the attempt and negative at the end. Since that distance is a continuous function of time, it must be 0 somewhere in between. If the barrier instead moves right, then the tactic will succeed if the coin is “tails”. In this case, the distance from E to  $Y-S$  is negative at the start and positive at the end, so E will necessarily be at  $Y-S$  at some time, which is equivalent to being at  $Y$  because of the periodicity of the barrier. If  $Y$  is smaller than  $X$ , then we again discover that the attempt will succeed as long as E and the barrier move in opposite directions. Regardless of which way the barrier moves, assuming as we do that the barrier’s movement is independent of the coin’s outcome, each attempt will succeed with probability at least 0.5. Since the coin flips are assumed to be independent, and since each attempt takes a time of at most  $S/U$  to accomplish, the mean time for E to achieve  $Y$  is at most  $2S/U$ .

The independence assumptions made above are required. If E’s motion were observable by the barrier, then the barrier could simply infer the outcome of the coin flip and imitate E’s motion, thus preventing E from moving relative to the barrier. The barrier could even arrange to always have a capture circle directly below E (recall  $V \geq U$ ). The ultimate success of E’s attempts depends on E’s movements being unobservable.

## 2. Trial Details

We now turn to the details of a trial. A trial consists of following a particular path. A “path” is closely related to a “track”, but not exactly the same thing. A track always starts from the middle of B in Figure 1, and continues to lead the barrier, following all barrier reversals, until it reaches the baseline, regardless of capture. The exact description of a track is entirely dependent on barrier reversals, rather than any decisions by E.

Figure 3 shows one possible track as four linked arrows. Segment B of Figure 1 is shown extending from  $-b$  to  $b$ , in the  $x$ - $y$  plane, and the segment G is shown as part of the upper boundary of the lower part, extending from  $-g$  to  $g$ . The endpoints of the segments B and G are connected by two capture boundaries with slope  $\phi$ , forming a trapezoid. For illustration purposes, the angle  $\phi$  is shown larger in Figure 3 than in Figure 1.

The track shown in Figure 3 has three barrier reversals. The segments pointing to the right (left) relative to the barrier correspond to periods when the barrier moves to the left (right) relative to the medium. The track is shown ending at a point  $x_f$  on the baseline

to the right of  $g$ . If E were to follow that track, he would be captured at the point on the third arrow where it crosses the right-hand capture boundary, thus failing to penetrate. In fact, any track ending at  $x_f$  must lie within the dashed cone, and must therefore be a failure because the left-hand side of the dashed cone encounters a capture boundary before encountering the baseline. A track will be successful if and only if it terminates within  $G$ , and the illustrated one does not.

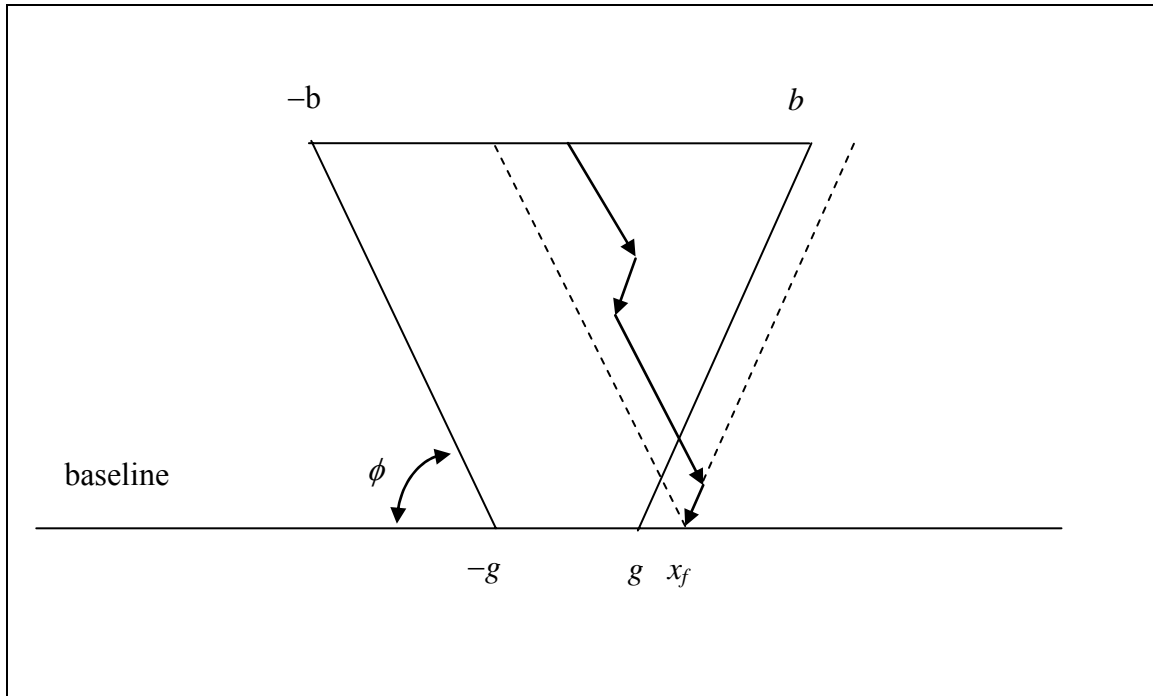

**Figure 3. Illustrating a track (solid with arrows) and its associated cone terminating at  $x_f$  (dashed).**

Now, E's only control over his path is through determining its starting point, which we take to be an independent random variable  $Y$  uniformly distributed over the interval  $B$  (getting to the starting point is the "setup" problem), and in deciding when to turn around to avoid capture. Except for those decisions, E follows the track that is dictated by barrier reversals, over which he has no control. The pictured track is unsuccessful when it starts at 0, but would be successful if the starting point were in the interval  $[-x_f - 2g, -x_f]$ . Any such translation will move the apex of the dashed cone to lie within  $G$ , while still leaving the starting point within  $B$ . Since the length of that interval is  $2g$ , and since the starting point of E's path is independent of the track's termination point, we can say that the probability of success for E's path, given that the track terminates to the right of  $G$ , is  $g/b$ . This statement is also true for tracks that terminate to the left of  $-g$  or within  $G$ , so we can make the unconditional statement that the probability of success for each trial is  $g/b$ . If E's path is not successful, it will be because he has turned around to avoid capture, and his arrival back on  $B$  will initiate the next trial.

To summarize a trial, E first selects a random starting point within  $B$ , and then moves downward at maximum deflection angle  $\phi$ , moving right or left relative to the

barrier depending on the direction of its motion. If E encounters a capture barrier before he encounters G, he retreats and the trial is a failure; otherwise, the trial is a success. The probability of success is  $g/b$ .

The maximum length of a trial occurs when the path encounters a capture barrier just before encountering the baseline, in which case E has to travel both directions, a total vertical distance of twice the height of the barrier strip, or  $4r$ . Since his vertical speed is  $U\cos(\phi)$ , the maximum length of a trail is  $\frac{4r}{U\cos(\phi)} = \frac{4rV}{U\sqrt{V^2-U^2}}$ .

The end points of B are the intersections of the linear upper edges of the dunce caps with the upper boundary, so the length of B is somewhat smaller than S. To be precise, the half-length is

$$b = g + 2r / \tan(\phi) = g + (2r/U)\sqrt{V^2-U^2}, \quad (2.2)$$

where  $g$  is as given by (2.1). Equations (2.1) and (2.2) thus determine the probability of success.

### 3. Mean Time to Penetration

The average number of trials to achieve the first success is  $b/g$ , the mean of a geometric distribution, and the amount of time per trial is the sum of the time between trials and the length of the trial itself. The total amount of time required for penetration is therefore, at most,

$$\tau \equiv \left(2\frac{S}{U} + \frac{4rV}{U\sqrt{V^2-U^2}}\right)\left(1 + \frac{r\sqrt{V^2-U^2}}{g}\right), \quad (2.3)$$

as long as  $g > 0$ . For example, if  $V = 5$ ,  $U = 4$ ,  $S = 4$ , and  $r = 1$ , the success probability is  $1/3$ , the average setup time is 2, the average length of a trial is (at most)  $5/3$ , and  $\tau=11$ . If  $g < 0$ , the barrier is perfect and penetration will never occur.

### C. SINGLE SEARCHER

In this section, we consider the case where there is exactly one searcher (capture circle) available to defend a barrier of length  $S$  that is fixed to the medium. In the classical analysis (Koopman, 1980; Washburn, 1982), E's motion is supposed to be in a straight line that is perpendicular to the barrier, and E does not have the option of simply evading the barrier. To imitate that with our smart E, we suppose that the barrier spans a long channel that E must stay within for physical reasons—imagine a long hallway or strait with parallel sides, as pictured in Figure 4. We also suppose that the searcher moves at speed  $V$  along some closed curve, a “patrol” as shown in the right-hand-side of the figure. The question we consider is “does there exist a patrol such that E cannot move from one side of the barrier to the other without being captured?”

We have no answer to the question, nor can we even propose a practical method for answering it. This should not be surprising, since the same situation holds even in the classical analysis where E's motion is required to be in a straight line. Instead, we propose two approximations.

The first approximation is to join the two edges of the channel together, thus forming a tube. Both the searcher and E are allowed to cross the seam, so the edges cease to be relevant, and the searcher now desires to separate one end of the tube from the other. This situation is equivalent to the straight-line analysis above in the sense that any straight-line motion for E can be translated to the tube, and vice versa, with identical consequences. A barrier is possible if and only if  $SU < 2r \max(U, V)$ . We conjecture that joining the channel edges favors the searcher.

The second approximation is to consider only barriers that move back-and-forth over a distance  $d$  that is less than  $S$ , overlapping the channel sides as shown in the left-hand side of Figure 4. Koopman (1980) recommends such barriers when the searcher's speed  $V$  is small compared to E's speed  $U$ , otherwise preferring "bow-tie" barriers that include a segment parallel to the channel sides. End effects are crucial, since moving along a channel side is a natural tactic for E. In order to be effective, the searcher must return to each end point before E is able to travel a distance  $x = 2\sqrt{r^2 - y^2}$  along one of the boundaries (the heavy line segment in Figure 4). Thus,  $2d/V$  cannot exceed  $x/U$ .

Instead of asking whether a particular  $S$  can be defended, we instead seek the maximum width of barrier that can be defended. This problem amounts to maximizing  $d + 2y$  subject to the constraint that  $\frac{d}{V} \leq \frac{\sqrt{r^2 - y^2}}{U}$ , a calculus exercise. The solution is that the ratio  $y/d$  should be  $2U^2/V^2$ , and the maximized value of  $d + 2y$  is

$$S^* \equiv \frac{r\sqrt{V^2 + 4U^2}}{U}. \quad (2.4)$$

The back-and-forth patrolling tactic will establish a barrier if and only if  $S < S^*$ . If  $(r, S, U, V) = (3, 10, 3, 4)$ , then  $S^* = \sqrt{52} = 7.2$ , so a barrier is not possible in that case, even though Koopman's formula produces a detection probability of 1.0. We see again the significant effect of E's being "smart".

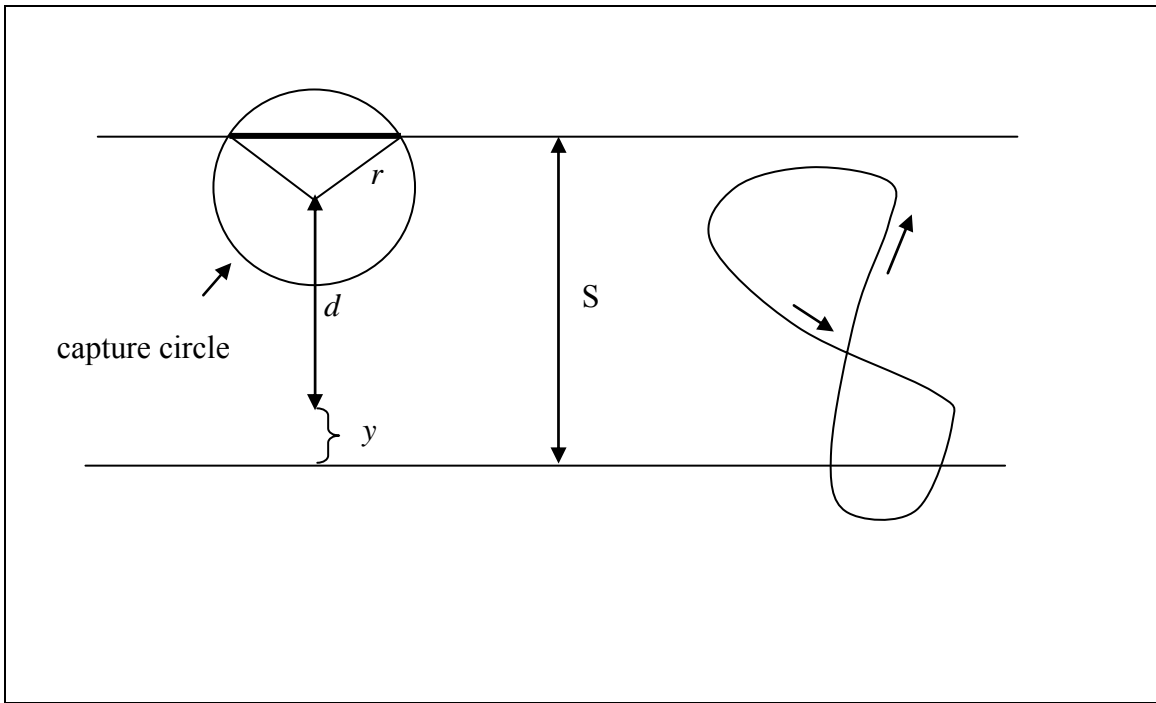

**Figure 4.** Showing a back-and-forth patrol (left) and a general patrol (right).

THIS PAGE INTENTIONALLY LEFT BLANK

### III. CIRCULAR BARRIERS

We now take up the case of circular barriers. The barrier line is replaced by a barrier circle of radius  $R$  with center  $O$ . Several ( $n$ ) capture circles (at least one, so  $n \geq 1$ ) with radius  $r$  have their centers evenly distributed on the circumference of the barrier circle. The capture circles remain fixed to the barrier, which rotates clockwise with angular speed  $V/R$  radians per unit time; that is, the center of each of the capture circles is always moving with speed  $V$ . Points outside the circle with center  $O$  and radius  $R + r$  are “outside”, while points inside the circle with center  $O$  and radius  $R - r$  are “inside”. The question is whether  $E$  can get from outside to inside without being captured. Typically,  $R$  is determined to be large enough to protect inside operations from actions by  $E$ .

We assume  $r \leq R$ , since otherwise the inside is empty and  $E$  has no chance. There is one other circumstance where  $E$  has no chance. Two capture circles that are tangent will be separated by an angle  $A \equiv \arcsin(r/R)$ , so if  $nA > 2\pi$ , the capture circles constitute a solid barrier that cannot be crossed, regardless of how fast  $E$  is. In either case, the barrier will be said to be “perfect”.

As long as the barrier is not perfect,  $O$  can be connected to the outside by a line that does not go into the interior of any capture circle, so a sufficiently fast  $E$  will be able to penetrate the barrier. Let  $U$  be  $E$ 's speed. We assume  $U > 0$ , since otherwise  $E$  cannot move and no capture circles at all are needed for a barrier. Let  $\mu \equiv U/V$ . Only the dimensionless ratio  $\mu$  is important to the penetration question, and, similarly,  $r$  and  $R$  are not important except through their ratio  $\rho \equiv r/R$ . The analysis below will be conducted in terms of these dimensionless ratios—we are essentially setting  $R$  and  $V$  to unity.

We again adopt a coordinate system relative to the barrier, as shown in Figure 5.  $E$ 's location is  $(z, \theta)$  in polar coordinates, with one of the capture circles (the “base”) located at angle  $0$ . On account of the clockwise rotation of the barrier,  $E$ 's motion is subject to a drift of magnitude  $zV$  directed perpendicularly to  $z$  and counterclockwise. This drift is the vector pointing from  $E$  to the center of the small circle in Figure 5.  $E$  can use his own speed to achieve any relative velocity pointing from  $E$  to any point within the small circle. A cone of feasible directions results. Figure 5 shows the two extreme possibilities for  $E$ 's relative velocity as dashed lines, one pulling the rotational velocity inwards, and the other outwards. The cone has an apex angle of  $2\phi$ , where  $\phi = \arcsin(U/zV) = \arcsin(\mu/z)$ . Note that  $\phi$  now depends on  $E$ 's location, whereas it does not in the case of a straight-line barrier. As  $E$  moves closer to  $O$ , the cone expands. If  $z < \mu$ , the cone becomes a circle; that is,  $E$  can move in any direction he chooses.

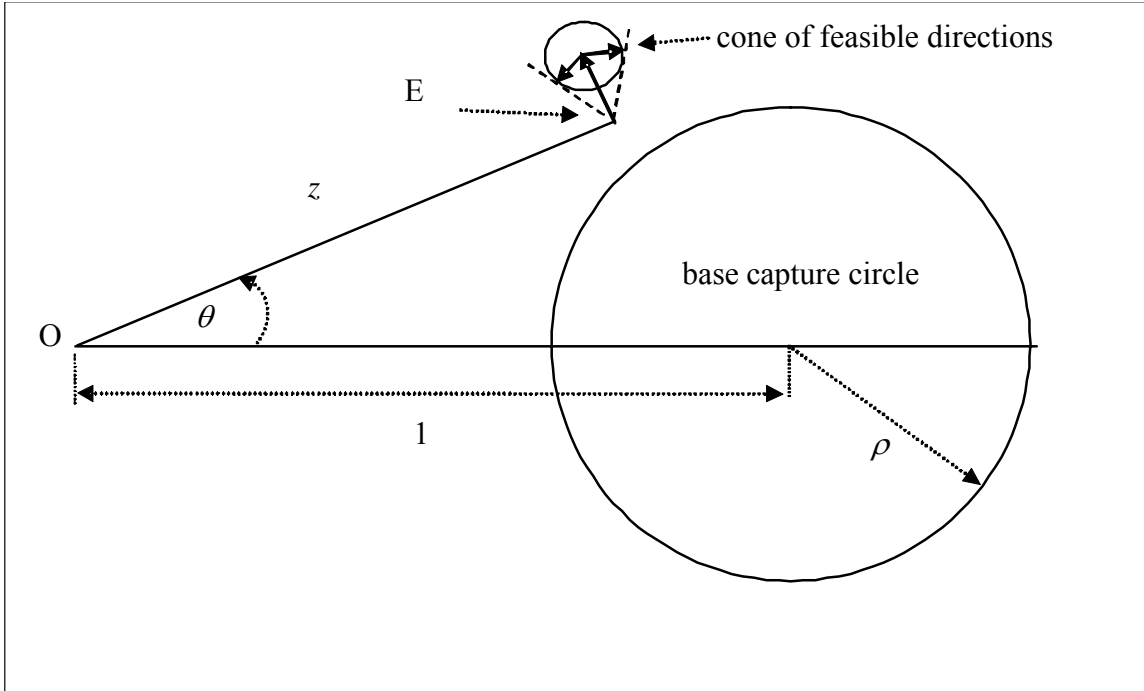
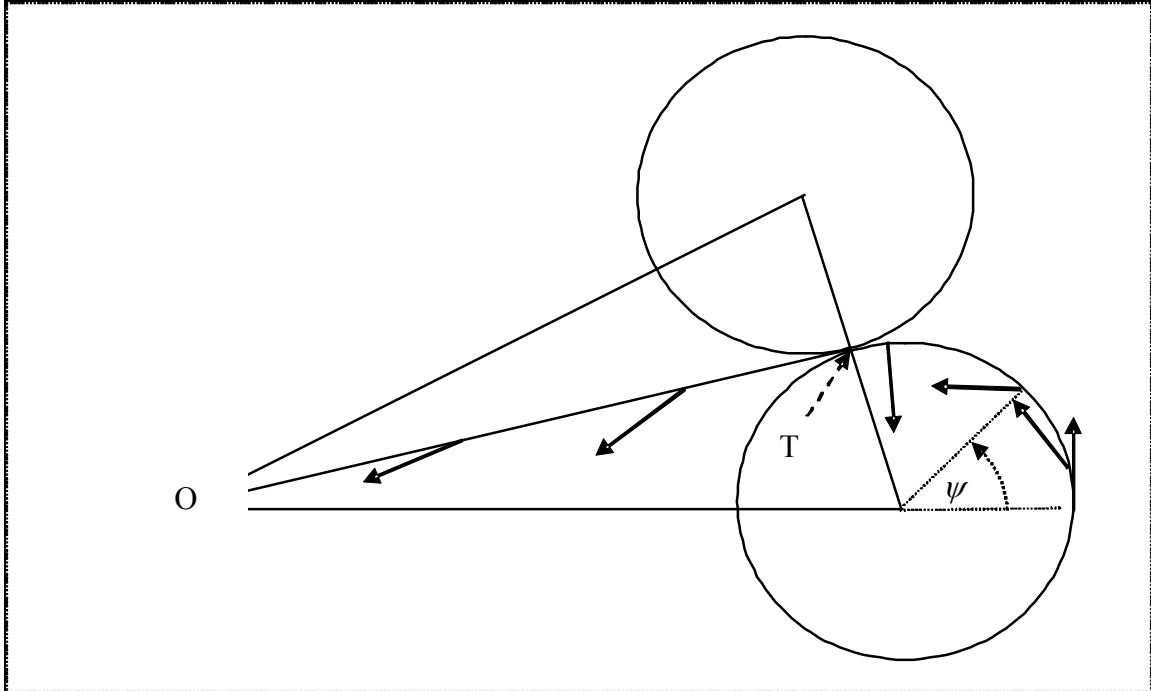

**Figure 5. E's position relative to the base capture circle, showing the cone of feasible directions.**

If  $\mu > 1$ , E can always penetrate unless the barrier is perfect, although the truth of that statement is not quite obvious because the outer edges of the capture circles may move faster than  $\mu$ . One way for E to do this is shown in Figure 6, where we assume the worst case where the capture circles are all tangent to each other. Two of the capture circles are shown. E starts at the outer edge of the base capture circle, follows the circumference of that circle counterclockwise until the tangent point T is reached, and then moves directly from T to the center of the barrier circle. The direction of E's velocity relative to the barrier is, of course, oriented along that path. The direction of E's velocity relative to the medium is shown in Figure 6 by solid arrows. When E is outside of T, the important point is that, since  $\mu > 1$ , E can keep the distance between himself and the center of the base capture circle (which moves with speed 1 through the medium) constant, with some excess speed to move toward T along the circumference. In doing this, he stays strictly within the cone of feasible directions, rather than using an extreme direction. He will be on the verge of capture until the point T, but will never enter the interior of a capture circle, and will therefore not be captured.

The tactic described above will not work when  $\mu = 1$  because of a problem encountered when the angle  $\psi$  is  $\pi/2$ . At that point, the velocity of the center of the base capture circle is pointed directly away from E at speed 1. To stay on the base circle, E would have to orient his speed vector in the same direction. This would keep E on the base circle, but would also leave him stationary. While E would not be captured, neither he would ever get inside. Some other tactic might work for E, but the one illustrated in Figure 6 will not. As long as  $\mu > 1$ , E can keep moving around the base circle even when  $\psi = \pi/2$ , the worst case, and can therefore safely get to T and then inside.



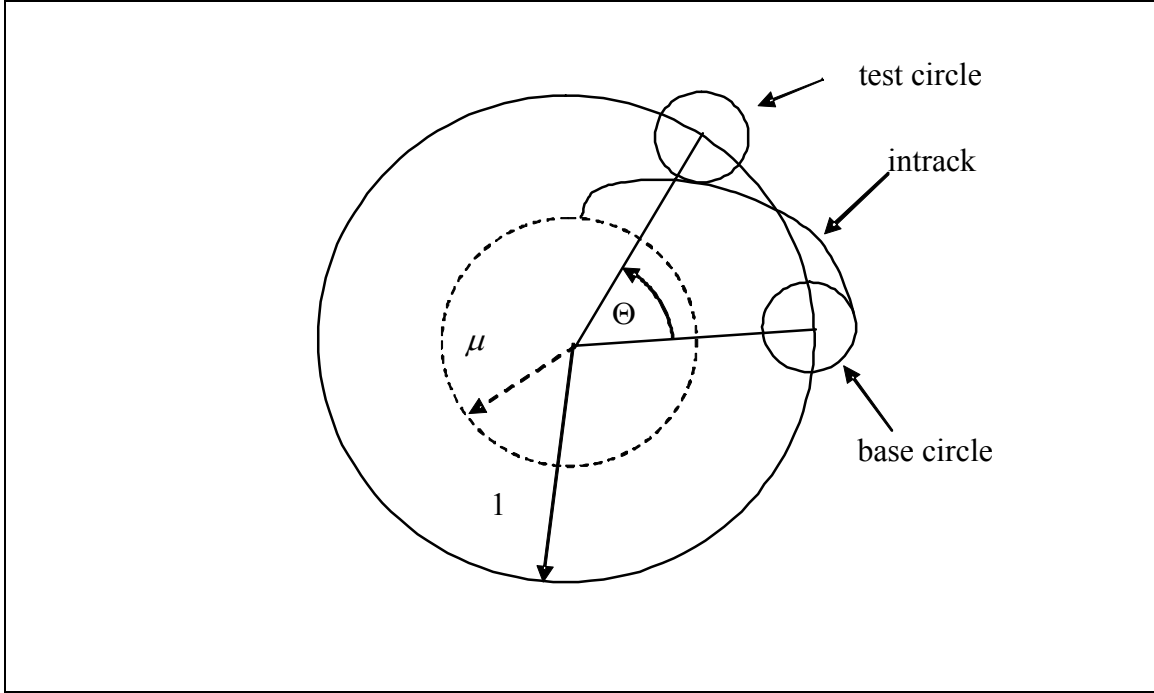

**Figure 6.** A successful penetration in the case where  $U > V$ .

We have now disposed of all cases where either  $\rho > 1$  or  $\mu > 1$  or  $\mu = 0$ .

If E is to penetrate an imperfect barrier when  $0 < \mu \leq 1$ , he will have to do so by passing between two capture circles that are either tangent, as in Figure 6, or which have some positive separation between them. E can still start out by following the back of some capture circle (we take it to be the base circle) for a while, but will eventually have to leave it. Once he leaves it, he should simply pull inwards, hoping to avoid the next approaching capture circle as well as the base circle. Since this tactic is independent of the position of the next capture circle, we leave its position indefinite for the moment.

To be precise, E will have to leave the base circle when the angle  $\psi$  shown in Figure 6 is the acute angle that satisfies  $\sin(\psi) = \mu$ , call it  $\psi_0$ , since that is the first point where E can just barely stay on the base circle by pulling radially outwards from its center. After that point, E should simply pull inwards, by which we mean that he should utilize the extreme inwards direction that the cone of feasible directions permits. To do otherwise would simply waste circumferential space. During the intervals when E is pulling inwards, he will follow a path that we will call an “intrack”. An intrack will spiral inwards, with  $\theta$  being an increasing function of time and  $z$  decreasing with  $\theta$ . Figure 7 shows an example.



**Figure 7. An intrack spiraling in to the  $\mu$ -circle, with a tangent test circle.**

Along an intrack,  $z$  obeys the ordinary differential equation

$$\frac{dz}{d\theta} = -z \tan(\phi) = -\frac{z\mu}{\sqrt{z^2 - \mu^2}}; z > \mu, \quad (3.1)$$

where the second equality in (3.1) follows from the fact that  $\sin(\phi) = \mu/z$ . The solution of this equation is

$$g(z/\mu) + \theta = K; \text{ where } g(x) = \sqrt{x^2 - 1} + \text{atan}(1/\sqrt{x^2 - 1}); x > 1, \quad (3.2)$$

and where  $K$  is a constant, as can be verified by differentiation. The function  $g(x)$  is a strictly increasing function of  $x$  that is approximately  $x$  when  $x$  is large. We take  $g(1)$  to be  $\pi/2$ , the limiting case as  $x$  approaches 1 from above. Should  $z$  decrease to  $\mu$  as  $\theta$  increases, then the intrack will be perpendicular to a circle with radius  $\mu$  about  $O$  (hereafter a “ $\mu$ -circle”). This is because (3.2) shows the slope being infinite at such a point. The intrack of Figure 7 spirals in from the base circle and terminates perpendicularly to the  $\mu$ -circle.

We can evaluate the constant  $K$  by taking account of where  $E$  leaves the base circle. Let  $(z_0, \theta_0)$  be  $E$ 's position at that point, and consider the triangle formed by  $O$ ,  $E$ , and the center of the base circle ( $B$ ), as shown in Figure 8.

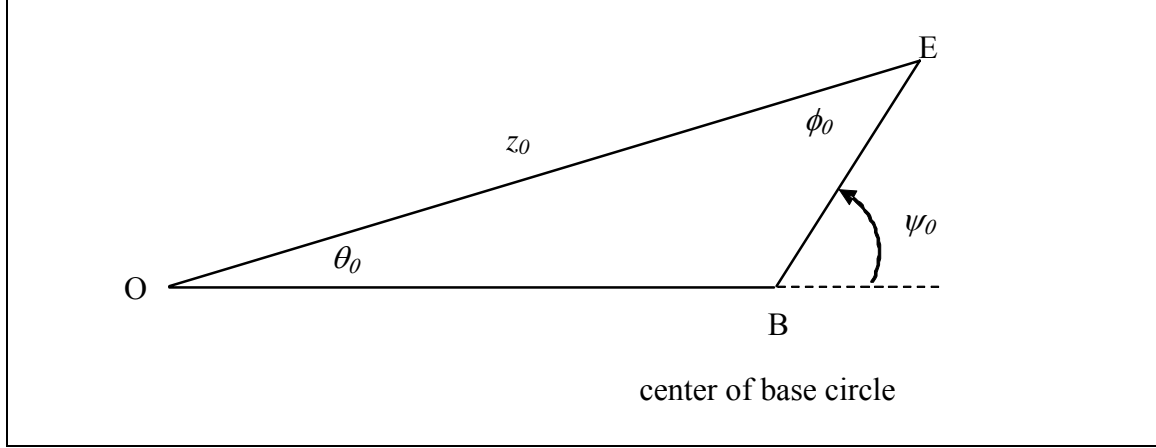

**Figure 8. Showing E's location as he departs the base circle on an intrack.**

Recall that  $\phi_0$  is the acute angle between the perpendiculars to lines OE and BE (the perpendicular to BE is tangent to the base circle, as is the intrack). The lines BE and OE must therefore have the same angle between them, as shown in Figure 8. By the law of cosines, and noting that  $\cos(\psi_0) = \sqrt{1 - \mu^2}$ ,

$$z_0^2 = 1 + \rho^2 + 2\rho\sqrt{1 - \mu^2}. \quad (3.3)$$

Since the sum of the angles in a triangle is  $\pi$ , we also have

$$\theta_0 = \psi_0 - \phi_0. \quad (3.4)$$

We can therefore evaluate  $K$  because (3.2) must be true at  $(z_0, \theta_0)$ . We first note that  $z_0^2 - \mu^2 = (\sqrt{1 - \mu^2} + \rho)^2$ , as can be verified by expanding the square on the right-hand-side and comparing to (3.3). Substituting this into 3.2, we have

$$K = g\left(\frac{z_0}{\mu}\right) + \theta_0 = \frac{\sqrt{1 - \mu^2} + \rho}{\mu} + \arctan\left(\frac{\mu}{\sqrt{1 - \mu^2} + \rho}\right) + \theta_0. \quad (3.5)$$

But,

$$\arctan\left(\frac{\mu}{\sqrt{1 - \mu^2} + \rho}\right) = \arcsin\left(\frac{\mu}{z_0}\right) = \phi_0. \quad (3.6)$$

So, by (3.4) - (3.6), we have

$$K = \frac{\sqrt{1 - \mu^2} + \rho}{\mu} + \psi_0. \quad (3.7)$$

Figure 7 also shows a “test” capture circle that is tangent to the intrack. The illustrated intrack will not be captured by either circle, since it enters the interior of neither one, but, if the test circle were any closer to the base circle, then it would be impossible for E to get between the two. Our objective is to determine the critical angle  $\Theta$  between the test circle and the base circle. If and only if there are enough capture circles

to make  $n\Theta > 2\pi$ , then E will not be able to penetrate a barrier of evenly spaced capture circles because each neighboring pair of capture circles will be separated by an angle smaller than  $\Theta$ . In determining an exact expression for this critical angle, we must consider several cases. We will do so in the order of increasing  $\mu$ .

**A. THE CASE:  $\rho^2 + \mu^2 \leq 1$**

When capture circles are tangent to each other, the tangency point will be a distance  $\sqrt{1 - \rho^2}$  from O. We will refer to points at that distance from O as the tangency circle, or “*t*-circle” for short. In the case being considered in this section, the  $\mu$ -circle lies inside the *t*-circle, as illustrated in Figure 7. If one imagines the test circle as starting at the base circle and then rotating clockwise until it first contacts the intrack, one of the possibilities is that first contact will be made at a point of tangency, as in Figure 7. Let  $(z_1, \theta_1)$  be E’s location at this point. As at the beginning of the intrack, E’s velocity must be directed radially outward from the center of the test circle, and must exactly cancel the velocity due to the barrier’s rotation. Consider the triangle formed by E, O, and the center of the test circle (B), as shown in Figure 9.

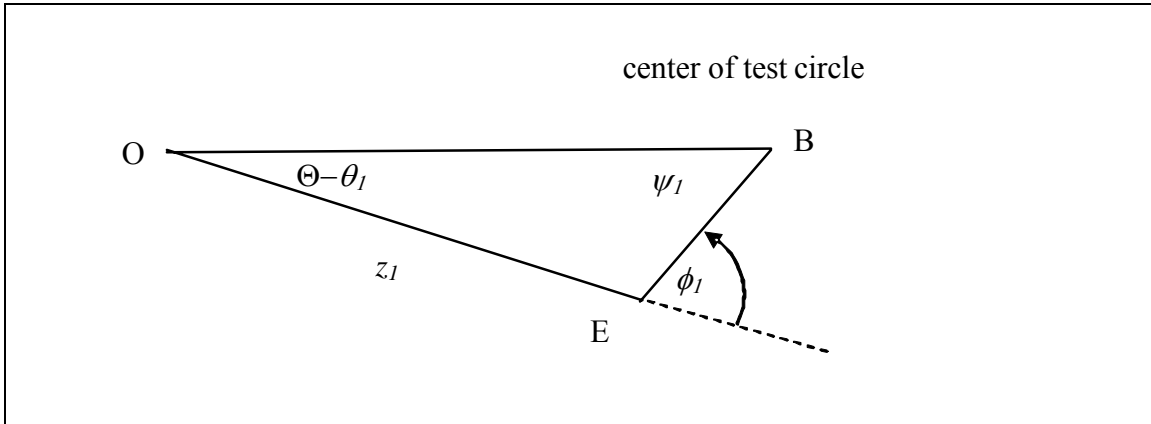

**Figure 9. Showing E’s location as he encounters the test circle on an intrack.**

In Figure 9,  $\psi_1$  is an acute angle for which the rate at which the distance between E and B changes is zero, which means that  $\sin(\psi_1) = \mu$ , which in turn means that  $\psi_1 = \psi_0$ . Solving for  $(z_1, \theta_1)$ , we find:

$$z_1^2 = 1 + \rho^2 - 2\rho\sqrt{1 - \mu^2} \quad \text{and} \quad \Theta - \theta_1 = \phi_1 - \psi_1. \quad (3.8)$$

Although  $z_1$  is smaller than  $z_0$ , it is still larger than  $\mu$ . This is because

$$z_1^2 - \mu^2 = (\sqrt{1 - \mu^2} - \rho)^2, \quad (3.9)$$

as can be seen by expanding the square on the right-hand-side and comparing to (3.9).

Since the right-hand side of (3.9) is the square of something nonnegative,  $\sqrt{z_1^2 - \mu^2} = \sqrt{1 - \mu^2} - \rho$ , and therefore  $\arctan\left(\frac{\mu}{\sqrt{1 - \mu^2} - \rho}\right) = \arcsin\left(\frac{\mu}{z_1}\right) = \phi_1$ . Thus

$$K = \frac{\sqrt{1 - \mu^2} + \rho}{\mu} + \psi_0 = g\left(\frac{z_1}{\mu}\right) + \theta_1 = \frac{\sqrt{1 - \mu^2} - \rho}{\mu} + \phi_1 + \theta_1. \quad (3.10)$$

But,  $\theta_1 + \phi_1 = \Theta + \psi_1$  from (3.8), and  $\psi_1 = \psi_0$ . After canceling terms in (3.10), we find the remarkably simple result that

$$\Theta = \frac{2\rho}{\mu}. \quad (3.11)$$

Equation (3.11) is valid even if  $\Theta > 2\pi$ , in the sense that the intrack might have to spiral around for several cycles in order to finally find a point of tangency with a test circle. If the tangency is not found within the first cycle, however, then the intrack will again meet the base circle, and E will be captured. The criterion for the base circle alone to be sufficient for an impenetrable barrier is therefore  $\rho > \pi\mu$ , a specific application of the general requirement that  $n\Theta$  must exceed  $2\pi$ .

There is one more remarkable characteristic of this case. Let  $(z_m, \Theta/2)$  be E's location on an intrack midway between the base circle and a test circle at angle  $\Theta$ . Then

$$g\left(\frac{z_m}{\mu}\right) = K - \frac{\Theta}{2} = \frac{\sqrt{1 - \mu^2} + \rho}{\mu} + \psi_0 - \frac{\rho}{\mu} = \frac{\sqrt{1 - \mu^2}}{\mu} + \arcsin(\mu) = g\left(\frac{1}{\mu}\right). \quad (3.12)$$

Since  $g()$  is a strictly increasing function, it follows from (3.12) that  $z_m$  must be 1. There is an implication for duncecaps. Just as we can define an intrack as a solution of (3.1), we can also define an outtrack as a solution of (3.1), but without its minus sign—this corresponds to E pulling outwards, rather than inwards, and has  $z$  increasing with  $\theta$ , rather than decreasing. An outtrack is simply an intrack with the sense of  $\theta$  reversed, so Figure 7 in essence displays an outtrack, as well as an intrack. In fact, if one reflects the part of the intrack where  $z < 1$  backwards from the radial where  $\theta = \Theta/2$ , one has an outtrack that is tangent to the base circle, as shown in Figure 10, and which intersects the intrack at the point  $(1, \Theta/2)$ , forming a duncecap. The apex of the duncecap is always on the barrier circle.

This completes the analysis of the case where E is relatively slow, which culminates in the simple result (3.11) for the angle  $\Theta$  that is controlled by each capture circle. The case where E is relatively fast is the subject of the next section.

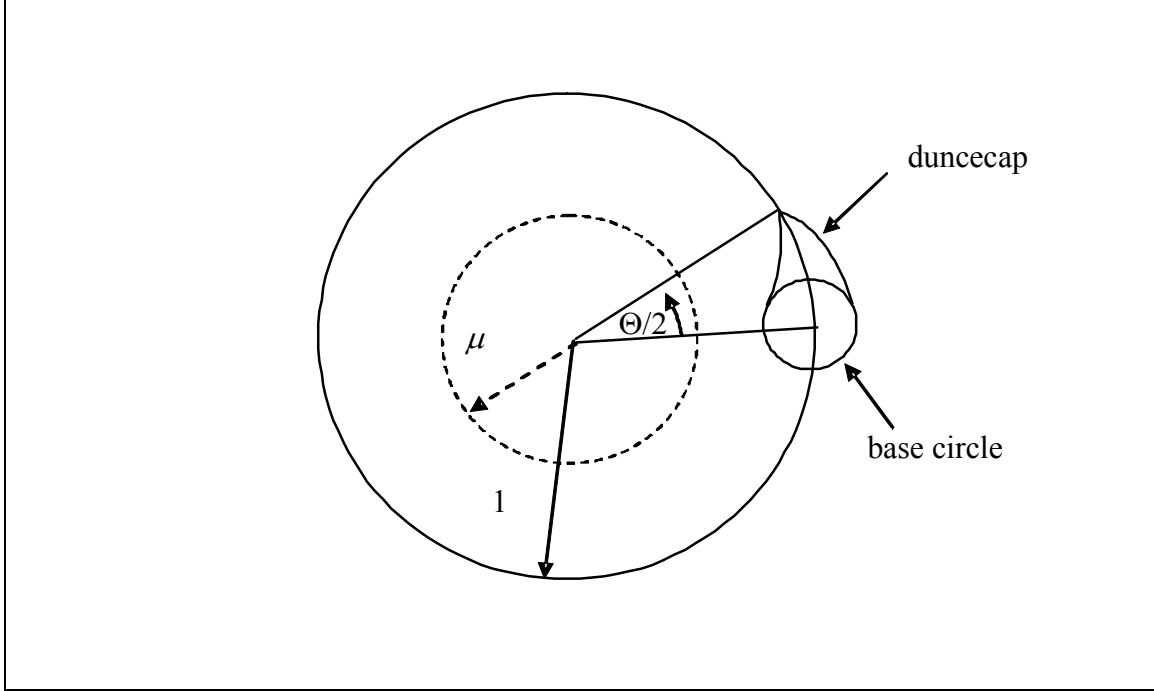

Figure 10. Illustrating a duncecap based on Figure 7.

**B. THE CASE:  $\rho^2 + \mu^2 > 1$**

The  $t$ -circle lies inside the  $\mu$ -circle in this section, whereas the opposite was the case in the previous section.

Figure 11 shows an intrack terminating on the  $\mu$ -circle, together with a test circle that is separated from the base circle by a critical angle  $\Theta_p$ . The angle  $\Theta_p$  in Figure 11 is a provisional critical angle – the true critical angle might be larger than  $\Theta_p$  for reasons that will be explained shortly. If the test circle were any closer to the base circle, then E could not get between them. The test circle in Figure 11 is *not* tangent to the intrack, but rather touches it at its endpoint on the  $\mu$ -circle. It cannot be tangent because the test circle is perpendicular to the  $t$ -circle at the point where they intersect, whereas the intrack is perpendicular to the  $\mu$ -circle, and the  $t$ -circle lies inside the  $\mu$ -circle. Once he reaches the terminus of the intrack, assuming that the barrier is not perfect, E can penetrate the barrier by following the test circle up to its intersection with the  $t$ -circle (E can move in any direction he chooses within the  $\mu$ -circle), and then simply move radially to get inside.

Let  $(z_1, \theta_1)$  be E's location at the terminus of the intrack, where  $z_1 = \mu$ . To determine  $\Theta_p$ , apply the law of cosines to the triangle BOE, with included angle  $\Theta_p - \theta_1$ . Since the lengths of all three sides are known, we can solve for  $\Theta_p - \theta_1$ :

$$\Theta_p - \theta_1 = \arccos\left(\frac{1 + \mu^2 - \rho^2}{2\mu}\right) \quad (3.13)$$

In (3.13), the argument of the  $\arccos()$  is always a number between 0 and 1. Since

$g\left(\frac{z_1}{\mu}\right) + \theta_1 = g(1) + \theta_1 = \frac{\pi}{2} + \theta_1 = K$ , we can solve for  $\theta_1$ :

$$\theta_1 = \frac{\sqrt{1-\mu^2} + \rho}{\mu} + \psi_0 - \frac{\pi}{2} = \frac{\sqrt{1-\mu^2} + \rho}{\mu} - \arccos(\mu). \quad (3.14)$$

Finally, summing (3.13) and (3.14), we have

$$\Theta_p = \frac{\sqrt{1-\mu^2} + \rho}{\mu} - \arccos(\mu) + \arccos\left(\frac{1+\mu^2-\rho^2}{2\mu}\right) \quad (3.15)$$

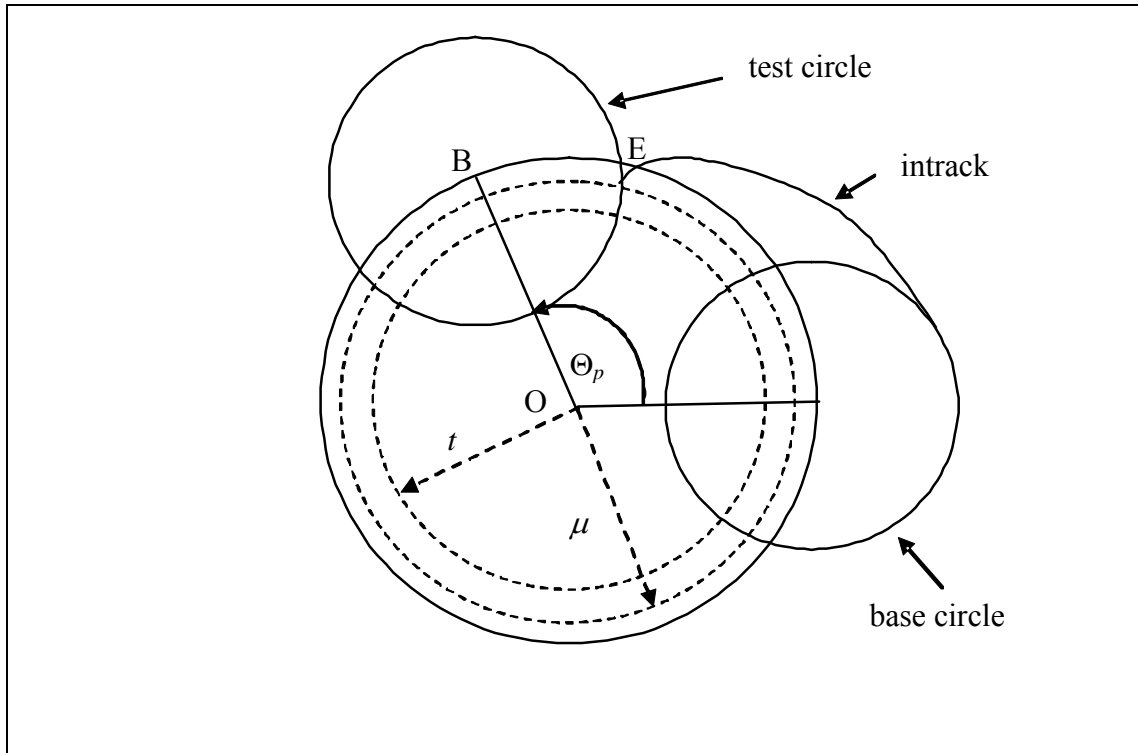

**Figure 11. An intrack hitting the  $\mu$ -circle and the test circle simultaneously.**

The subscript on  $\Theta_p$  is necessary because the two capture circles might overlap on the  $t$ -circle, in which case E could not penetrate in spite of avoiding capture throughout the intrack. This possibility is easily accounted for, since the angle between two tangent capture circles is  $2\arcsin(\rho)$ . Therefore, the true critical angle is

$$\Theta = \max\{\Theta_p, 2\arcsin(\rho)\}. \quad (3.16)$$

Like (3.11), (3.16) is not bounded above by  $2\pi$ . A single capture circle will suffice when  $\Theta$  exceeds  $2\pi$ .

Unfortunately, we have still not quite accounted for all of the possibilities. It can happen that the intrack will leave the base circle and then run into the base circle again

before encountering the  $\mu$ -circle, as illustrated in Figure 12. This happens if  $\rho = \mu = 0.98$ , for example. This may be counterintuitive, since E leaves the base circle reluctantly for lack of sufficient speed. Why would he subsequently be able to re-enter it? The answer is that E becomes faster relative to the rotational speed with which he must compete as  $z$  decreases, to the extent that consistently pulling inward can bring the intrack back to the base circle. When this happens, clearly E should not continue to follow the intrack, since doing so would lead to immediate capture, but rather should follow the base circle all the way to the  $t$ -circle, and then move radially inward. E will penetrate unless the capture circles overlap. As long as the intrack stays within the base circle until it encounters the  $\mu$ -circle, (3.16) is still correct because it will correctly conclude that  $\Theta = 2\arcsin(\rho)$ .

However, suppose that an intrack were to enter the base circle, but then come out again and ultimately terminate on the  $\mu$ -circle at an angle  $\theta$  that exceeds  $\arcsin(\rho)$ . In that case, (3.16) would give an answer that is too large—the tactic for E described above will always penetrate unless the capture circles overlap. While we do not have a proof that that cannot happen, it has not come even close to happening in extensive numerical investigations. We conjecture that it never happens, and that (3.16) is correct.

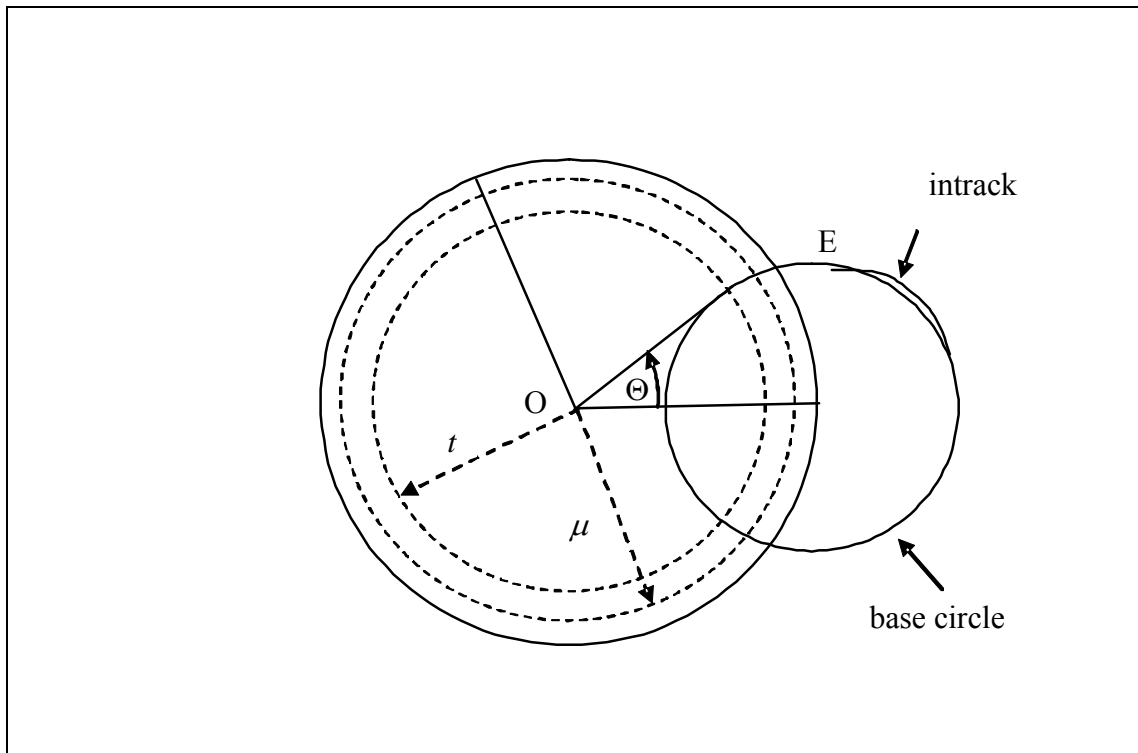
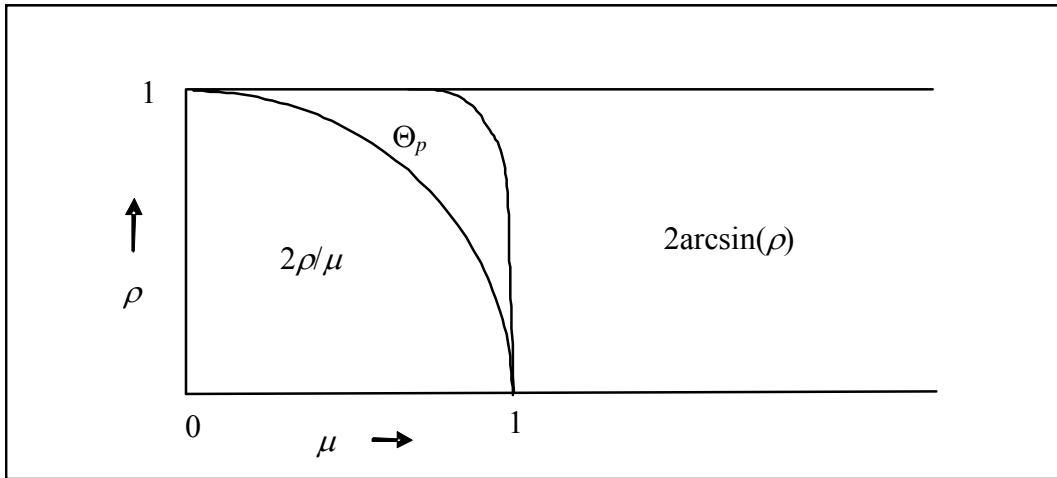

**Figure 12.** An intrack entering the base circle.



### C. SUMMARY OF THE CIRCULAR CASE

Figure 13 shows how the critical angle  $\Theta$  depends on  $\rho$  and  $\mu$  for  $0 \leq \rho \leq 1$  and  $\mu > 0$ , with different formulas in three different regions. The function  $\Theta$  is continuous across the two boundaries shown. The boundary between  $2\rho/\mu$  and  $\Theta_p$  is a quarter-circle. The boundary between  $\Theta_p$  and  $2\arcsin(\rho)$  is approximate—we do not have an analytic expression for the boundary where (3.16) switches between its two component formulas. The terminus of that boundary when  $\rho=1$  is at about  $\mu=0.638$ . When  $\rho=1$  and  $\mu > 0.638$ ,  $\Theta = \pi$  and three capture circles are required to prevent E's success. When  $\rho=1$  and  $0.318 < \mu < 0.638$ ,  $\Theta$  is between  $\pi$  and  $2\pi$ , and two capture circles suffice. When  $\rho=1$  and  $\mu < 0.318$ , one capture circle is enough.



**Figure 13. Dependence of the critical angle  $\Theta$  on  $\rho$  and  $\mu$ .**

A Microsoft Excel™ workbook, *CircleBarrier.xls*, can be downloaded from <http://faculty.nps.edu/awashburn/>. The workbook is useful for exploring the computations related to circular barriers. It also includes Visual Basic code for determining the critical angle  $\Theta$ , the function being *theta(rho, mu)*. This function returns  $\Theta = 7$  if  $\rho$  exceeds 1. Any other number exceeding  $2\pi$  would do as well, since the only implication is that one capture circle suffices. Here is the code:

```

Function theta(rho, mu)
' rho is the ratio of the capture circle radius to the barrier radius
' mu is the ratio of penetrator speed to the capture circle speed
' mu is positive, rho nonnegative
' Acos is the arc cosine function
Dim rho2, mu2, perfect
If rho < 0 Or mu <= 0 Then
    theta = 1 / 0 'deliberately create an error
End If
rho2 = rho * rho
If rho > 1 Then
    theta = 7
    Exit Function
Else
    perfect = 2 * Acos(Sqr(1 - rho2))
End If
mu2 = mu * mu
If mu > 1 Then
    theta = perfect
ElseIf rho2 + mu2 <= 1 Then
    theta = 2 * rho / mu
Else
    theta = (rho + Sqr(1 - mu2)) / mu + Acos((1 + mu2 - rho2) / (2 * mu)) - Acos(mu)
    If theta < perfect Then
        theta = perfect
    End If
End If
End Function

```

#### **D. BARRIER REVERSALS**

If the angular distance between two capture circles exceeds  $\Theta$ , then there is a positive gap between them that E can eventually penetrate, just as in the linear case. Each trial will begin with E positioning himself at a random point on the outer edge of the barrier, and then following an intrack until it either enters the gap or encounters the boundary of a duncecap, in which case E would retreat on an outtrack to try again another day. The arguments are so similar to those in the linear case that we will spare the reader the details. Regardless of the barrier reversal policy, E will eventually penetrate the barrier in exactly the same circumstances where he would do so without barrier reversals.

## LIST OF REFERENCES

Koopman, B. (1980). *Search and Screening*. Pergamon, Chapter 8.

Washburn, A. (1982). On Patrolling a Channel. *Naval Research Logistics*, 29, pp. 609-615.

THIS PAGE INTENTIONALLY LEFT BLANK

## INITIAL DISTRIBUTION LIST

1. Research Office (Code 09).....1  
Naval Postgraduate School  
Monterey, CA 93943-5000
2. Dudley Knox Library (Code 013).....2  
Naval Postgraduate School  
Monterey, CA 93943-5002
3. Defense Technical Information Center.....2  
8725 John J. Kingman Rd., STE 0944  
Ft. Belvoir, VA 22060-6218
4. Richard Mastowski (Technical Editor).....2  
Graduate School of Operational and Information Sciences (GSOIS)  
Naval Postgraduate School  
Monterey, CA 93943-5219
5. Distinguished Professor Alan Washburn.....5  
Department of Operations Research  
Naval Postgraduate School  
Monterey, CA 93943
6. Professor James Eagle.....1  
Department of Operations Research  
Naval Postgraduate School  
Monterey, CA 93943-5219
7. Senior Lecturer Jeffrey Kline, CAPT, USN (Ret.).....1  
Department of Operations Research  
Naval Postgraduate School  
Monterey, CA 93943-5219
8. Naval Undersea Warfare Center.....1  
Combat Systems Department  
ATTN: Dr. Chidambar Ganesh  
Newport, RI 02841
9. Center for Naval Analyses.....1  
4825 Mark Center Drive  
Alexandria, VA 22311

10. NMAWC.....1  
ATTN: Tom Little  
32444 Echo Lane  
BLDG 1/Suite 300  
San Diego, CA 92147-5119
11. Surface Warfare Development Group .....1  
ATTN: Mr. Dave Gilbert, Technical Director  
2200 Amphibious Drive  
Norfolk, VA 23521-2896