

9<sup>th</sup> International Symposium on Technology and Mine Problem, NPS, Monterey California, USA, 17-20 May 2010

## **Tail Separation and Surface Impact Effects on the Underwater Trajectory of the JDAM**

Peter C. Chu<sup>1</sup>, Jillene M. Bushnell<sup>1</sup>, and Kennard P. Watson<sup>2</sup>

<sup>1</sup>*Naval Postgraduate School*, <sup>2</sup>*NSWC-PC (Sponsored by ONR, Program Manager: Brian Almquist)*

### **Abstract**

The Navy is in need of an organic, inexpensive, swift method to neutralize or sweep waterborne mines. This paper presents an alternative to current mine countermeasure technologies that fulfill this criteria - the use of the Joint Direct Attack Munition (JDAM) to clear a minefield. Our experimental and modeling study strongly suggest high efficiency of the JABS for mine clearance in the very shallow water (depth less than 12.2 m).

**Keywords:** Stand-off Assault Breaching Weapon Fuse Improvement (SOABWFI), 3D underwater bomb trajectory model, semi-empirical drag/lift/torque coefficients, STRIKE35

### **1. Introduction**

Study on the movement of a fast-moving rigid body through water column has wide scientific significance and technical application [1-4]. Recently, such a scientific problem drew attention to the naval research. This is due to the threat of mines in the naval operations. Mines are prolific. Many options exist to neutralize mines, but all options have advantages and disadvantages. For example, the mine countermeasure ship (SMCM) is effective but slow and not suitable for a shallow water operation. The mine countermeasure airplane (AMCM) can tow the very capable sled (with the MK-103 through MK-106 installed) into shallow water, but is unable to work in low visibility or at night. The explosive ordnance disposal technicians are excellent, but their limitations come from fatigue, water temperatures, and water depth. Beyond the risk they are taking being in the water, if the water is murky enough to restrict vision, their risk increases. Marine mammals, though excellent at hunting mines and currently our only asset for detection of buried mines, do not neutralize mines due to the risk involved with handling explosives [5-9].

In order to reduce the risk to personnel and to decrease the sweep timeline without sacrificing effectiveness, a new concept has been developed to use the Joint Direct Attack Munition (JDAM, i.e., ‘smart’ bomb guided to its target by an integrated inertial guidance system coupled with a global positioning system)

Assault Breaching System (JABS) for mine clearance (Fig. 1). The JDAM accuracy, repeatability and fuzing options make the JABS a prime contender for an interim capability. Combined with bomber range and payload capability, this weapon system vastly improves joint operations, especially the effectiveness of JABS as a mine neutralizer in the surf and beach zones [10-11].

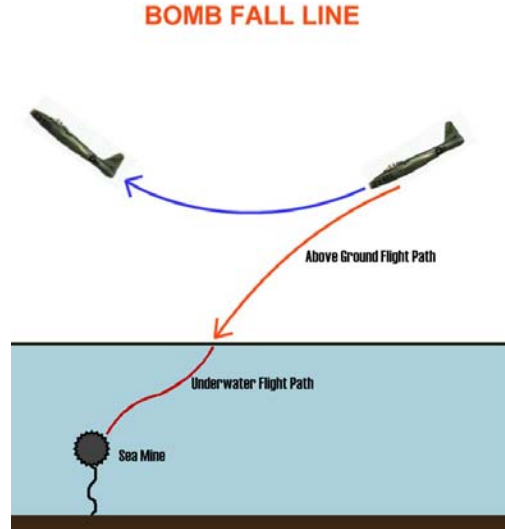

Fig. 1. The concept of airborne sea mine clearance.

## 2. A 6-DOF Model (STRIKE35)

The earth-fixed coordinate system is used with the unit vectors ( $\mathbf{i}$ ,  $\mathbf{j}$ ) in the horizontal plane and the unit vector  $\mathbf{k}$  in the vertical direction. The origin of the coordinate system is chosen at the impact point at the water surface [12-13]. Consider an axially symmetric rigid body such as a JDAM falling through water column. The two end-points of the body (i.e., head and tail points) are represented by  $\mathbf{r}_h(t)$  and  $\mathbf{r}_t(t)$ . The body's main axis (Fig. 2a) direction is denoted by

$$\mathbf{e} = \frac{\mathbf{r}_h - \mathbf{r}_t}{|\mathbf{r}_h - \mathbf{r}_t|}. \quad (1)$$

The centers of mass ( $o_m$ ) and volume ( $o_v$ ) are located on the main axis with  $\sigma$  the distance between  $o_v$  and  $o_m$ , which has a positive (negative) value when the direction from  $o_v$  to  $o_m$  is the same (opposite) as the unit vector  $\mathbf{e}$  (Fig. 2b). The location (or called translation) of the body is represented by the position of  $o_m$ ,

$$\mathbf{r}(t) = x\mathbf{i} + y\mathbf{j} + z\mathbf{k}. \quad (2)$$

The translation velocity is given by

$$\frac{d\mathbf{r}}{dt} = \mathbf{u}, \quad \mathbf{u} = U\mathbf{e}_u, \quad (3)$$

where  $(U, \mathbf{e}_u)$  are the speed and unit vector of the rigid-body velocity. The momentum equation of the rigid body is given by,

$$m \frac{d\mathbf{u}}{dt} = \mathbf{F}_g + \mathbf{F}_b + \mathbf{F}_d + \mathbf{F}_l + n\mathbf{F}_c^f, \quad (8)$$

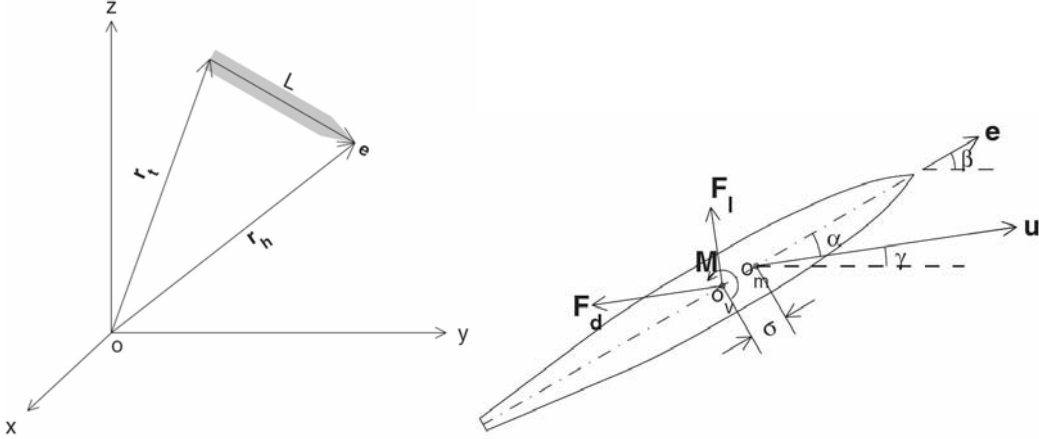

Fig. 2. (a) Position vectors ( $r_h, r_t$ ) and the body axis unit vector ( $\mathbf{e}$ ), and (b) orientations, centers of mass and volume, and forces of a JDAM.

where  $m$  is the mass of the rigid body,  $(\mathbf{F}_g, \mathbf{F}_b)$  are the gravity and buoyancy force and  $\Pi$  is the volume of the rigid body.  $\mathbf{F}_d$  is the drag force on the non-tail part, which is in the opposite direction of the rigid-body velocity.  $\mathbf{F}_l$  is the lift force.

Let  $\mathbf{\Omega}^*$  be the rigid-body's angular velocity vector, which is decomposed into two parts with one along the unit vector  $\mathbf{e}$  (bank angle) and the other  $\mathbf{\Omega}$  (azimuthal and elevation angles) perpendicular to  $\mathbf{e}$ ,

$$\mathbf{\Omega}^* = \Omega_s \mathbf{e} + \mathbf{\Omega} \quad (13)$$

Let  $\mathbf{e}_\omega$  be the unit vector in the direction of  $\mathbf{\Omega}$ ,

$$\mathbf{\Omega} = \Omega \mathbf{e}_\omega, \quad \Omega = |\mathbf{\Omega}|. \quad (14)$$

The moment of momentum equation (relative to center of mass) is given by [1],

$$J_1 \frac{d\Omega_s}{dt} = -M_s, \quad (16)$$

$$J_2 \frac{d\mathbf{\Omega}}{dt} = \hat{\mathbf{M}} \quad (17)$$

where  $(J_1, J_2)$  are the first two components of the gyration tensor  $\mathbf{J}$ .  $M_s$  is the scalar part of resistant torque to self spinning (i.e., the torque paralleling to  $\mathbf{e}$ ), and  $\hat{\mathbf{M}}$  is the torque perpendicular to the unit vector  $\mathbf{e}$ .

### 3. Exercises

As reported in [1, 15, 16], the 1/12<sup>th</sup> scaled Mk-84 bomb moves at a high velocity through the water and flow separation creates a cavity of air around the body. That cavity then remains in the water long after the bomb has passed and causes two areas of concern. First, will the trajectory remain stable, or will it tumble inside its own air cavity? Second, when the bomb does hit the cavitation wall, will the tail fins break? In addition, what happens to the trajectory after the fins break?

A program entitled “Stand-off Assault Breaching Weapon Fuze Improvement (SOABWFI)” was developed and sponsored by the Office of Naval Research to collect data to evaluate and measure the underwater trajectory deviation for JDAMs through 12.2 m (or shallower) of water during guided releases from an airplane (FA-18E/F). All weapons impacted the target ponds at approximately a 90° angle (i.e., perpendicular to the flat water surface). During the experiment, the surface impact point and the horizontal deviation in the trajectory after going through the water column were measured [18-19].

#### 3.1. Test Ponds and Targets

Two frustum ponds were created in the Naval Air Warfare Center, Weapons Division (NAWC/WD) in the middle of Indian Wells Valley, California for the experiment. Both ponds have a circular bottom with the same diameter of approximately 30.5 m and different sizes. The smaller pond is about 7.6 m deep and the larger is about 12.2 m deep. Sloping sides (2:1) create a surface diameter of roughly 61 m for the smaller pond and 79 m for the larger diameter. A ramp was built into the side of each pond for vehicle access. A plastic liner covers the dirt to contain the brackish water that is supplied by a 206 m deep, on-site well that filled both ponds at about 800 gallons per minute. Placed inside the water are fully operational, moored, foreign mines filled with simulant, instead of TNT (Fig. 3).



Fig. 3. Artificial ponds used for the flight tests at NAWC/WD.

### 3.2. Instrumentations

High-speed digital cameras, light sensors, pressure sensors, and a global positioning system (GPS) were used to collect the data. The range cameras capture 60 frames per second and the two Phantom cameras capture 1,000 frames per second. These cameras recorded the location, speed, and orientation of the weapon at the time of water impact (Fig. 4a). Using orthogonal images from the Phantom cameras, the water impact AOA can be observed. The light and pressure sensors provide the time and depth of detonation for the inert weapons equipped with a fuze and booster. The booster fires at the same time as the fuze, sending out a pressure pulse and light flash that is picked up by the sensors. The horizontal deviation of the weapon in the pond is determined by comparing the distance between the water impact and pond bottom impact. The images from cameras determine the water location and the Trimble 5800 GPS system locates the pond bottom impact location surveying the holes (Fig. 4b).

### 3.3. Aircraft and Weapons

An F/A-18F Super Hornet, proceeding at 0.8 Mach, dropped live and inert GBU-31s from 10,668 m (i.e., 35,000 ft) above the mean sea level. Release occurred approximately 8-11 km from the pond in order to give the glide weapon enough kinematic energy to orient itself vertically above the designated point of impact (DPI). The desire is to have the velocity vector aligned with the munitions axis (zero AOA), and both vectors perpendicular to the flat, water surface. All of the GBU-31s penetrated the water within the prescribed delivery error of less than 2 m Circular Error Probable (CEP) at velocities between 382.5 and 394.9 m/s.



**Fig. 4. (a) High speed digital camera, and (b) GPS for surveying impact holes.**

Every JABS in the experiments had the MXU-735 nose cone (Fig. 5) and the tail telemetry (TM) kit installed. The bluntness of the nose cone forces a larger cavitation tunnel for the weapon to proceed through. The TM provides data, via line of sight transmission, on various flight parameters such a velocity, heading, altitude, and angle of attack. Since there is not a line of sight from the

pond to range control, the TM's lowest data transmission was about 32.9 m above the pond. The weapons that had fuzes were equipped with an FMU-139 B/B with available delay settings of 0, 10, 25, and 60 msec. Selection of the delay depends on which types of targets the weapon is to attack. The explosive in the live weapon is PBXN-109, whereas the inert weapons have filling to maintain appropriate weight and balance.

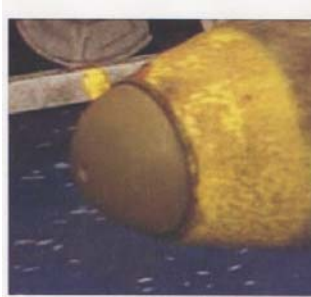

**Fig. 5. The MXU-735 nose cone used in SOABWFL.**

### **3.4. Underwater Trajectory Tests**

When a JDAM moves at a high speed through the water column, the flow separation creates a cavity of air around the body. That cavity, sometimes called cavitation, then remains in the water long after the bomb has passed and causes two areas of concern. Questions arise: Will the trajectory remain stable, or will it tumble inside its own air cavity? Will the tail fins break when the JDAM hits the cavitation wall? What happens to the trajectory after the fins break? The underwater trajectory tests (UTT) were conducted collecting data for the JDAM's underwater location and trajectory in order to answer these questions. On the other hand, the data can be used to verify the Navy's 6-DOF model (i.e., STRIKE35).

All the three tests prove stability of the weapon to a certain depth in the water column, regardless of tail or fin separation. They also show that the tail fins most likely do (and the tail section possibly does) not remain intact during the full descent to the pond's bottom, regardless of the impact AOA. During UTT-1, no underwater video camera was used. During UTT-2, camera images strongly suggest the first weapon's tail impacted the cavity wall when the tail was about 1.5 m below the surface (the nose was around 5.5 m in depth), starting the process of breaking pieces off of the tail section, ultimately separating all four tail fins from the body. The second JADM also lost its fins. In the case of UTT-2(2), the bomb penetrated the bottom at such a shallow angle that it was able to burrow under the pond liner, climb the North face of the pond wall for a distance, re-enter the water traveling upward, and subsequently get airborne again. This is a strong indicator that the JDAM's tail fins broke off far enough above the bottom of the

pond to allow it to turn in the water. After dropping the JDAMs during UTT-1 and UTT-2, the ponds were drained. The trajectory deviation at the bottom ( $\Delta$ ) was observed (Fig. 6).

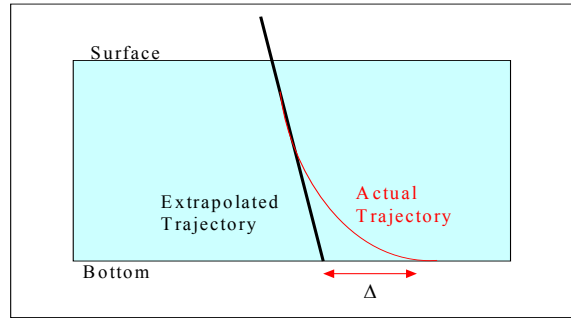

**Fig. 6. JDAM's trajectory deviation  $\Delta$ .**

#### **4. Sensitivity Studies**

The JDAM drop experiments were costly and only seven drops were conducted. With the seven drops, it is hard to find the effect of water impact speed, AOA at the surface, and tail fin breaking on the JDAM's trajectory deviation. For this challenge, we may fulfill this task using the 6-DOF model simulation including tail fin breaking option.

##### **4.1. Effect of Surface Impact Condition**

To investigate the effects of surface impact speed and AOA on the trajectory deviation, the 6-DOF model was integrated from the initial conditions consisting varying surface impact speed (381.0 m/s to 396.2 m/s) and AOA at the surface ( $1.0^\circ$  to  $3.4^\circ$ ). The water density is chosen as  $1027 \text{ kg/m}^3$  (characteristic value of sea water) [24]. In each case, the weapon's fins immediately fall off when the nose reaches a depth of 3.3 m and the weapon travels to a depth of exactly 12.2 m (i.e., 40 ft water depth). The modeled trajectory deviation ( $\Delta$ ) at the bottom shows its high dependence on surface impact speed and AOA (Fig. 7). All impact velocities, except 381 m/s, start out traversing the water with a pitch back trajectory. Between the impact AOA of about  $1.1^\circ$  and  $1.9^\circ$ , the weapon transitions to the single curve trajectory style and remains within the Technology Transition Agreement (i.e.,  $\Delta = 2.1 \text{ m}$ ). For above  $2^\circ$  of AOA, the weapon experiences flip-flop trajectory for all the surface impact speeds. The best case for remaining within the limits of the Technology Transition Agreement for the greatest range of AOA are impact airspeeds of about 387.1 to 390.1 m/s which allow an impact AOA of up to between  $2.4^\circ$  and  $2.5^\circ$ . The upper and lower limit of our sample, 381 m and 396.2 m, both only allow up to  $2.1^\circ$  AOA before departing the margin (i.e.,  $\Delta = 2.1 \text{ m}$ ).

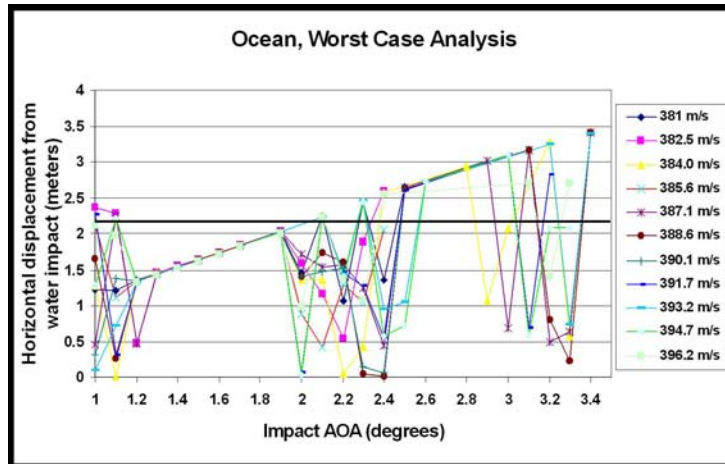

Fig. 7. Weapon displacement vs. AOA in a hypothetical ocean mixed layer

#### 4.2. Effect of Fuze Delay Time

The SOABWFI Flight Tests used the 10 msec delay on the FMU-139 fuze for the 7.6 m pond demonstrations (LFFD-1 and UTT-1) and the 25 msec delay for the 12.2 m pond demonstrations (UTT-2). The third delay, not used yet in the SOABWFI program, is the 60 msec delay. This fuze also has a  $\pm 20\%$  tolerance that can detonate the bomb within the time limits. The model is run at each delay setting, at its lower limit (delay time  $\times 80\%$ ), and at its upper limit (delay time  $\times 120\%$ ). The 6-DOF model was integrated from various surface impact conditions with inert GBU-31 JDAM's configuration (tail section with four fins) to the delay time [delay time  $\times (1 \pm 20\%)$ ], and then integrated with time from the JDAM's velocity and angular velocity vectors with the tail and fins removed to the bottom (i.e., 12.2 m). For a delay time of 10 msec, the horizontal deviation at 12.2 m depth increases with the surface impact AOA almost monotonically. However, it is less than 1.8 m no matter the surface impact speed or AOA, even with the upper bond (delay time  $\times 120\%$ ) (Fig. 8). For a delay time of 25 msec, the horizontal deviation at 12.2 m depth increases generally with the surface impact AOA, and is less than 2.1 m in the most cases except for the upper bonds with the surface impact AOA of  $5^\circ$  to  $6^\circ$ . Though the lowest impact speed (381 m/s) has a greater deviation for the surface impact AOA less than  $3^\circ$ , the highest speed (396.2 m/s) always has the greatest variation and has the highest deviation for the surface impact AOA larger than  $3^\circ$ . For a delay time of 60 msec delay, the horizontal deviation at 12.2 m depth is larger than 2.1 m in almost all the cases except few occasions. All of the surface impact speeds and AOA up to  $3^\circ$  remain within about 8 m of the water impact point.



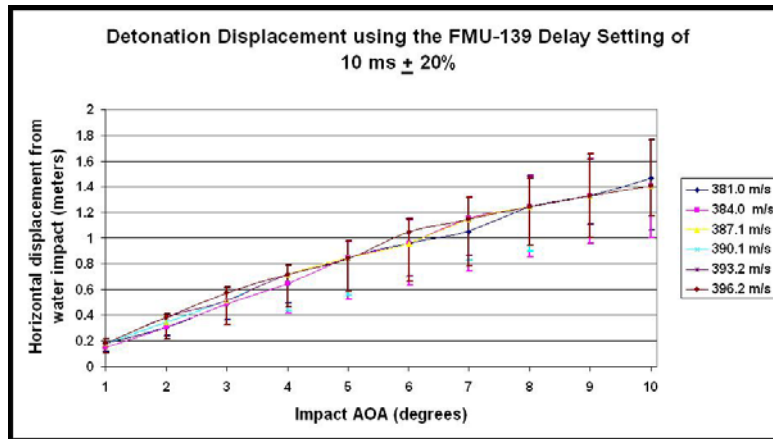

Fig. 8. Weapon displacement vs. AOA for 10 msec  $\times(1 \pm 20\%)$  delay

## 5. Conclusions

The experimental and 6 DOF-modeling studies were conducted in this study. They show the feasibility of using the Joint Direct Attack Munition Assault Breaching System (JABS) for mine clearance. The experiments include the seven JDAM drops from the F/A-18E/F Super Hornet to the two ponds (depths: 7.6 m, 12.2. m) in the Naval Air Warfare Center, Weapons Division (NAWC/WD). The horizontal drift of the JDAM at the bottom ( $\Delta$ ) was by draining the water after the drops and by underwater high-speed video cameras. The values of  $\Delta$  vary from 0.11 m to 0.72 m, which are within the Technology Transition Agreement between the Office of Naval Research and the Navy (i.e., 2.1 m). This strongly suggests high efficiency of the JABS for mine clearance in the very shallow water (depth less than 12.2 m). The 6-DOF model (i.e., STRIKE35) with the same water impact conditions as in the experiments leads to comparable results as obtained from the experiments. This also confirms the validity of the 6-DOF model in prediction of JDAM's location and trajectory in the water column.

Dependence of the effects of surface impact speed, AOA, and the fuze delay time on the horizontal drift at the water depth of 12.2 m was investigated using the 6-DOF model. It was found that surface impact speed having little bearing on the overall horizontal trajectory of the weapon from the water impact point. However, the surface AOA has larger effect. The specific fuze settings and their tolerances in the ocean environment, finding the 10 msec fuze to have no limitations and the 25 msec to be limited below  $4^\circ$ . For a large fuze delay time (such as 60 msec), the horizontal deviation at 12.2 m depth is much larger than the criterion (i.e., 2.1 m).

## Acknowledgments

Office of Naval Research Breaching Technology Program (Grant Number: N0001410WX20165, Program Manager: Brian Almquist) supported this study.

## References

- [1] Chu, P.C., Fan, C.W., and P. R. Gefken, 2010. "Diagnostic-photographic determination of drag/lift/torque coefficients of high speed rigid body in water column." ASME J. Appl. Mech., 77, 011015-1- 011015-15.
- [2] Chu, P.C., and Fan, C.W., 2006. "Prediction of falling cylinder through air-water-sediment columns." AMSE J. Appl. Mech., 73, 300-314.
- [3] Chu, P.C., 2009. "Mine impact burial prediction from one to three dimensions." ASME Appl. Mech. Rev., 62 (1), 010802 (25 pages), DOI: 1115/1.3013823.
- [4] Chu, P.C., and Fan, C.W., 2007. "Mine impact burial model (IMPACT35) verification and improvement using sediment bearing factor method." IEEE J. Ocean. Eng., 32 (1), pp. 34-48.
- [5] Boorda, J. M., ADM, USN. Circa. 1996. "CSS Mine Countermeasures CNO White Paper: Mine Countermeasures - An Integral Part of Our Strategy and Our Forces." Web page, [accessed 9 July 1999]. Available at <http://www.ncsc.navy.mil/CSS/Papers/cnopaper.htm>.
- [6] Elmore, P. A., Wilkens, R., Weaver, T., and Richardson, M. D., 2005, "IMPACT 28 and 35 Simulations of 2003 Baltic Sea Cruise: Model Results and Comparison with Data," Fifth Annual ONR Workshop on Mine Burial Prediction, Kona, HI, Jan. 31–Feb. 2.
- [7] Chu, P.C., and Ray, G., 2006. "Prediction of High Speed Rigid Body Maneuvering in Air-Water-Sediment Columns," Adv. Fluid Mech. Vol 6, pp. 123-132.
- [8] Bruhn D., 2007. "Wooden ships and iron men: the U.S. Navy's ocean minesweepers, 1953-1994." Heritage Books, Inc., Westminster, Maryland, pp. 368.
- [9] Naval Studies Board, 2001. *Naval Mine Warfare: Operational and Technical Challenges for Naval Forces*. National Academy Press, Washington DC, pp. 218.
- [10] Almquist B., 2008. "Assault breaching system technologies." East Coast Amphibious and Mine Countermeasure Workshop; Sep 9-10, 2008, Panama City, Florida.
- [11] Almquist B, and McLaughlin T., 2008. "Assault breaching system technologies." 99<sup>th</sup> Annual Science and Engineering Annual Technology Conference/DoD Tech Exposition; Apr 15-17, 2008, Charleston, South Carolina.
- [12] Chu, P.C., Fan, C.W., Evans, A.D., and Gilles, A., 2004. "Triple coordinate transforms for prediction of falling cylinder through the water column." ASME J. Appl. Mech., 71, pp. 292-298.
- [13] Chu, P.C., and Fan, C.W., 2005. "Pseudo-cylinder parameterization for mine impact burial prediction." ASME J. Fluids Eng., 127, pp. 1515-1520.
- [14] Rouse, H., 1938, *Fluid Mechanics for Hydraulic Engineers*, McGraw-Hill, New York.
- [15] Gefken, P. R., 2006. *Evaluation of Precision-Guided Bomb Trajectory Through Water Using Scale-Model Experiments*. SRI Final Technical Report No. PYU-16600, pp. 50.
- [16] Ray G., 2006. *Bomb Strike Experiments for Mine Clearance Operations*. MS Thesis in Meteorology and Physical Oceanography, Naval Postgraduate School, Monterey, California, pp. 197.
- [17] Chu, P.C., Gilles, A., and Fan, C.W., 2005. "Experiment of falling cylinder through the water column." Exp. Therm. Fluid Sci., 29, pp. 555-568.
- [18] Chu, P.C., Almquist, J.B., Gefken, P., and Watson, K., 2009. "Underwater Bomb Trajectory Prediction for Stand-off Assault Breaching Weapon Fuse Improvement (SOABWFI)." *European Undersea Defense Technology – Europe*, Carnes, France, 9-11 June 2009.
- [19] Watson K, Makarsky J, Powell M, Goeller J., 2009. "Flight test to determine underwater stability of a precision guided weapon for use in mine clearance." 11<sup>th</sup> Joint Classified Bombs/Warheads & Ballistics Symposium; 2009 Aug 3-6; Monterey, CA.
- [20] Hale, J.S., 2009. *Stand-off Assault Breaching Weapon Fuze Improvement (SOABWFI) Underwater Trajectory Test - 1 (UTT-1)*. Boeing Report, No. 09J0059, pp. 33.
- [21] Crussel, R., 2009a. *Stand-off assault breaching weapon fuze improvement (SOABWFI) underwater trajectory test - 2 (UTT-2)*. Boeing Report, No. 09J0142, pp.13.
- [22] Crussel, R., 2009b. *Stand-off assault breaching weapon fuze improvement (SOABWFI) live fire flight demonstration -1 (LFFD-1)*. Boeing Report, No. 09J0078, pp. 35.
- [23] Humes, G., 2007. *Technology Transition Agreement, EC SHD-FYO6-03 FNC Product: Standoff Assault Breaching Weapon Fuze Improvement*.
- [24] Bushnell, J. M., 2009. *Tail Separation and Density Effects on the Underwater Trajectory of the JDAM*. MS Thesis in Meteorology and Physical Oceanography, Naval Postgraduate School, Monterey, California, pp. 83.